

Vocia[®]

VO-4

Operation Manual

January 2012

IMPORTANT SAFETY INSTRUCTIONS

- 1) Read these instructions.
- 2) Keep these instructions.
- 3) Heed all warnings.
- 4) Follow all instructions.
- 5) Do not use this product near water.
- 6) Clean only with dry cloth.
- 7) Do not block ventilation openings. Install in accordance with the manufacturer's instructions.
- 8) Do not install near any heat sources such as radiators, heat registers, stoves, or other product (including amplifiers) that produce heat.
- 9) Do not defeat the safety purpose of the grounding-type plug. A grounding type plug has two blades and a third grounding prong.

The third prong is provided for your safety. If the provided plug does not fit into your outlet, consult an electrician for replacement of the obsolete outlet.
- 10) Protect the power cord from being walked on or pinched particularly at plugs, convenience receptacles, and the point where they exit from the product.
- 11) Only use attachments/accessories specified by the manufacturer.
- 12) Use only with equipment rack, cart, stand or table designed to provide adequate mechanical strength, heat dissipation and securement to the building structure.

When a cart is used, use caution when moving the cart and product combination to avoid injury from tip-over. 
- 13) Unplug this product during lightning storms or when unused for long periods of time.
- 14) Refer all servicing to qualified service personnel. Servicing is required when the product has been damaged in any way, such as power-supply cord or plug is damaged, liquid has been spilled or objects have fallen into the product, the product has been exposed to rain or moisture, does not operate normally, or has been dropped.

WARNING - To reduce the risk of fire or electric shock, do not expose this product to rain or moisture.

WARNING - This product employs Safety Grounding and must be connected to a MAINS socket that is properly grounded to provide a protective earthing connection.

Disconnect Device - The MAINS plug is used to disconnect MAINS power and must be installed near the equipment and remain readily accessible.

Explanation of safety related symbols - Product labeling and the operation manual may use the internationally recognized symbols defined below to note safety messages.



Lightning Bolt: Hazardous Live voltages present when this unit is in operation. Do not touch terminals marked with this symbol while the unit is connected to live power.



Exclamation Point: Replace components (i.e. fuses) only with the values specified by the manufacturer. Failure to do so will compromise safe operation of this unit.

TABLE OF CONTENTS

VOCIA OUTPUT 4 (VO-4) FEATURES	4
FRONT PANEL	5
Setup and Use	5
1. Power Indicator LED	5
2. Signal LEDs	5
3. Control LEDs	5
REAR PANEL CONTROLS	6-8
Device ID	6
CobraNet	6
Network Connection	6
Control Outputs	8
Control Inputs	8
Audio Inputs	8
Ground Screw	8
INSTALLATION.....	9
SPECIFICATIONS & BLOCK DIAGRAM.....	10
WARRANTY	11
FCC COMPLIANCE.....	12
EC DECLARATION	13
EU ROHS COMPLIANT	14

VOCIA OUTPUT 4 (VO-4)

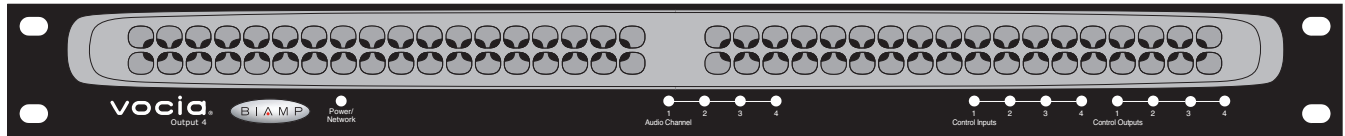

The VO-4 is a networked audio output expansion device allowing the user to add four line-level output channels to a Vocia® system. The VO-4 accepts four channels of digital audio input via CobraNet® and provides four line-level analog audio outputs. The VO-4 features embedded DSP and on-board memory to process and store all device-specific configuration information locally and includes comprehensive, fixed-chain, digital-signal processing. As part of the Vocia system, the VO-4 meets paging requirements for facilities of all sizes.

FEATURES

- Converts digital to analog
- Four removable terminal block connectors for line-level outputs
- Four control inputs and four control outputs
- Software-configurable local audio signal processing, including gain, filters, and compressor/limiter
- Rotary switches for unit identification
- Power Over Ethernet (PoE)
- CobraNet audio/control on single cable
- Status LEDs to indicate signal and clip
- **CE** marked and **RoHS** compliant
- Covered by BIAMP Systems' warranty

VO-4 FRONT PANEL

Setup and Use

The Vocia software provides an intuitive interface for configuration, DSP equalization, and programming of the VO-4. The information supplied by this manual relates to physical connections and assignment. For more details on software setup, please consult the Vocia Help File.

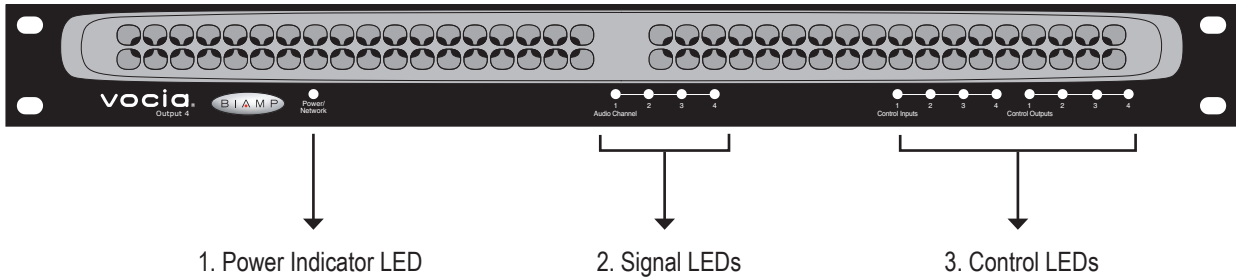

1. Power Indicator LED

On the left of the front panel, the VO-4 has a single LED that indicates power and connectivity status:

1. Not illuminated: The device is not powered.
2. Flashing green: The unit is receiving power but not data, or the unit has not been configured correctly.
3. Solid green: The unit is operational, has been configured and is receiving PoE.

2. Signal LEDs

Four LEDs located in the center of the front panel act as audio signal identifiers for the four input channels and are useful for setting optimum signal levels. Each LED has four states. Please see the table below for the signal mapping to each of the LEDs. Detailed metering of current output levels

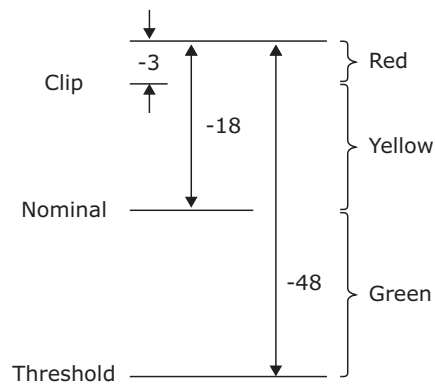

Red	Yellow	Green	Dark
Signal above clip threshold > -3dBFS	Signal above nominal but below clip threshold > -18dBFS < -3dBFS	Signal above minimum but below nominal threshold > -48dBFS < -18dBFS	Signal below minimum threshold < -48dBFS

can be obtained in real time via the Vocia software interface.

3. Control LEDs

The control LEDs signal the current state of the control I/Os. The first four are input status indicators, and the second four are output status indica-

Yellow	Green	Dark
Relays are energized	> input threshold	Not active

VO-4 REAR PANEL CONTROLS

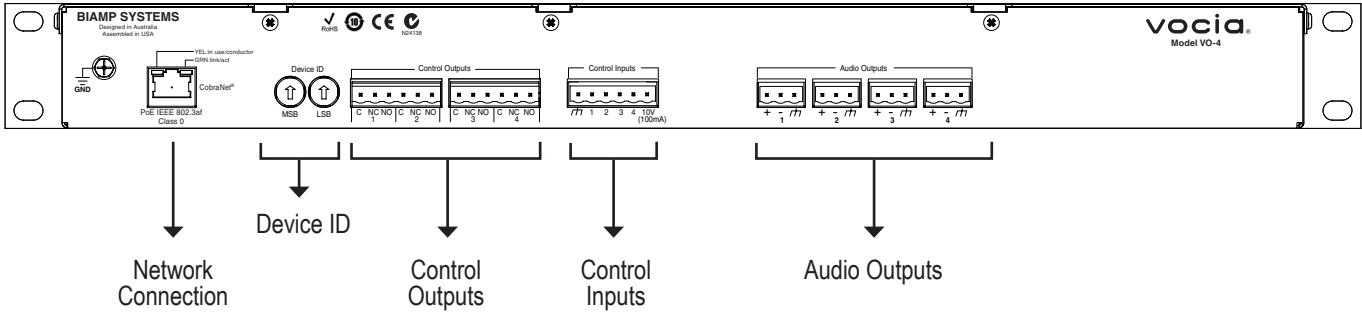

Network Connection

The VO-4 has one RJ45 connector located on the rear panel that utilizes standard Ethernet cabling to interface the VO-4 to the Vocia system via a managed network switch. The RJ45 connector provides two LEDs that indicate Ethernet link and network activity (see table below).

Left LED	Right LED	Description
None	None	No power or data connectivity. Please check the PoE network connection.
Green	None	Link established.
Green	Flashing amber	Link established and CobraNet activity detected; the unit is acting as a CobraNet performer.
Flashing green	Flashing amber	Link established and CobraNet activity detected; the unit is operating as a CobraNet conductor.
Flashing amber	Flashing amber	CobraNet fault. Check cabling and configuration for errors.

Device ID

The rotary ID switches are located on the back of the VO-4 and give the unit a unique Device ID. The switches are in hexadecimal format. All VO-4 units must have a unique Device ID to function properly within a Vocia Paging World (i.e., it is not possible to have two VO-4 units with the same Device ID of hex 07). To assign a Device ID of hex 07, turn the LSB switch to 7 and leave the MSB switch on 0. To create an ID of hex B7, turn the LSB switch to 7 and turn the MSB switch to B. Device ID switches should be set using a 0.1 inch (2.5mm) to 0.12 inch (3.0mm) flat blade screwdriver. More information on setting IDs and the hexadecimal numbering scheme used in Vocia can be found in the Vocia Help File.

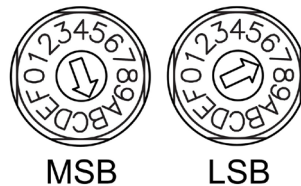

Please note: Changes made to the Device ID while connected to the network require a power cycle in order to take effect.

CobraNet

The VO-4 is a CobraNet device. All CobraNet routing and bundle assignments are processed by the Vocia devices locally. Vocia devices are not interoperable with non-Vocia devices.

VO-4 REAR PANEL CONTROLS

This connection carries control data, power, and digital audio over CobraNet. The maximum distance between any unit and an Ethernet switch is 328 feet (100 meters) when using copper cabling. Additional Ethernet switches and/or fiber-optic cable can be used to further extend distances between units on a network. Please note that CobraNet limits network extensions to seven hops (one-way transmissions) within a network.

If other network traffic shares an Ethernet switch with the Vocia network, a managed switch should be used with separate VLANs. All Ethernet wiring is to be done using shielded CAT5, CAT5e, CAT6, or CAT7 cable.

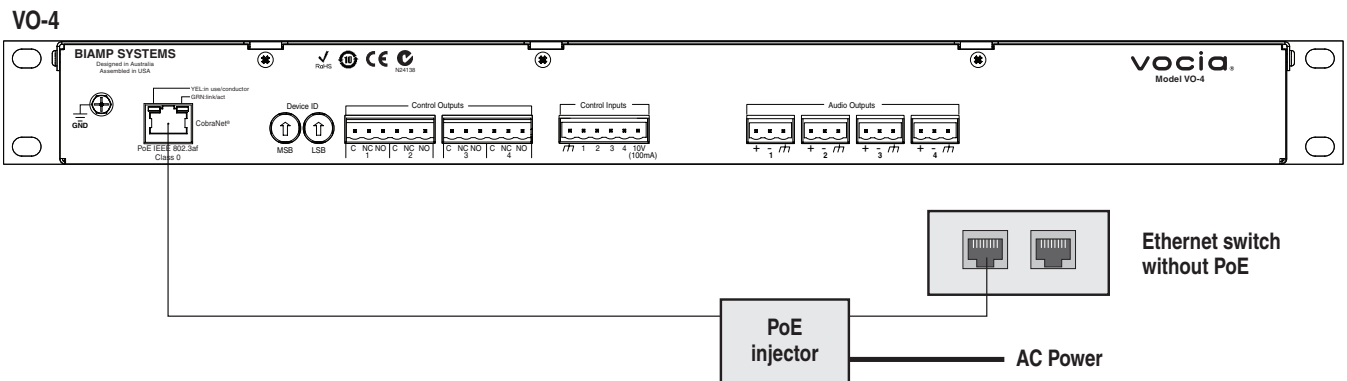
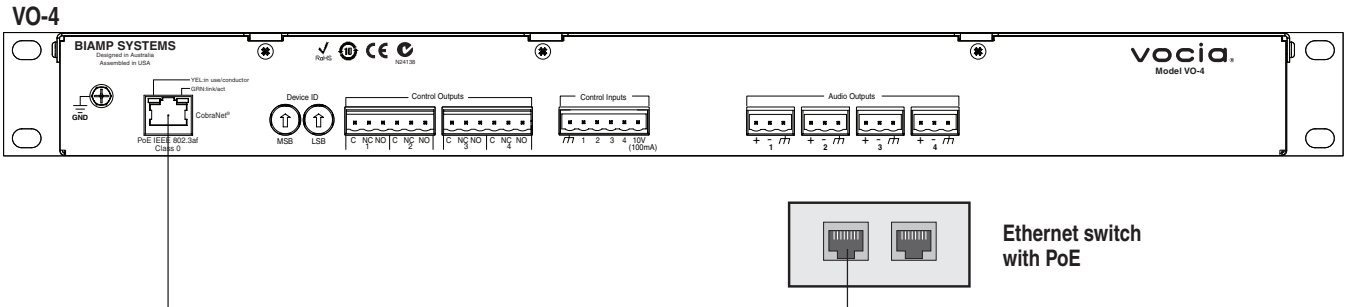

VO-4 REAR PANEL CONTROLS

Control Outputs

The Control Outputs, labeled 1 through 4, are isolated, voltage-free, software-configurable relay outputs.

The individual pins are labeled as follows:

1. (C): the common/ground pin
2. (NC): normally closed (connected to C when relay is not energized)
3. (NO): normally open (connected to C when relay is energized)

Control Inputs

The Control Inputs are labeled as follows:

1. (\overline{A}): logic common/ground input pin
2. (1–4): individual logic inputs
3. (10V): 10V reference voltage (when used as a switch input, a switch must be connected between the input and logic common terminal)

Audio Inputs

Four plug-in barrier strip connectors provide analog audio signal output. The Vocia software enables a nominal output level of +4 dBu, 0 dBu, or -10 dBu to support a wide range of connection devices. All plug-in barrier strip connectors should be wired from left to right as follows:

1. (+) High
2. (-) Low
3. (\overline{A}) Ground

Ground Screw

This screw provides a connection point to ground the chassis of the VO-4. The power supply to the VO-4 is sourced from PoE, which may have no connection to ground. The chassis of the VO-4 should be connected to a safety ground (main power supply ground) using the Ground Screw



VO-4 INSTALLATION

Installation

The VO-4 requires one 1.75 inches (44.45mm) high and 19 inches wide rack space with 10 inches (254mm) depth. Mounting the unit using four screws with washers will prevent marring of the front panel. PVC or nylon washers are appropriate.

Please install the unit away from heat sources, such as vents and radiators, and in rooms with adequate ventilation. Ensure that air can circulate freely behind, beside, and above the unit. Do not exceed the maximum ambient operating temperature of 113 degrees F (45°C). Be aware of conditions in an enclosed rack that may cause the temperature to exceed ambient room conditions.

VO-4 SPECIFICATIONS

Vocia Output 4 SPECIFICATIONS

Frequency Response:	20Hz to 20kHz + or - 1dB	Control Outputs	Type: Form C Voltage free change over contact
THD + N (20Hz to 8kHz):	<0.02%	Max Operating Voltage:	125VAC, 60VDC
Dynamic Range:	>80dB	Max Switching Capacity:	37VA
Crosstalk (10kHz):	>80dB	Min Operating Load:	10µA @ 10mV DC
Minimum Load Impedance:	600kΩ	Connection:	RJ45 with shielded Ethernet/PoE cable (CAT5, CAT5e, CAT6 or CAT7)
Maximum Output Level:	>+22dBu	Power:	802.3af (PoE) Class 3
Nominal Output Level:	-10dBu, 0dBu, or +4dBu	Dimensions:	Height: 0.75 inches (44.5mm) Width: 19 inches (483mm) Depth: 10 inches (254mm)
A/D Converters:	24-bit (48kHz sampling)	Weight:	6.4 lbs. (2.9kg)
Control Inputs:	Type: Digital, variable threshold	Ambient Operating Temperature Range:	32-113 degrees F (0-45 degrees C)
Max Input Threshold:	10V	Compliance:	FCC Part 15, class B CE marked RoHS Directive
Max Input Voltage:	12V		UL 60065 Listed, E215636
Min Input Threshold:	150mV		C-UL Listed, E215636
Input Impedance:	100kΩ		C-Tick, N24138 (Australia)

Vocia Output 4 BLOCK DIAGRAM

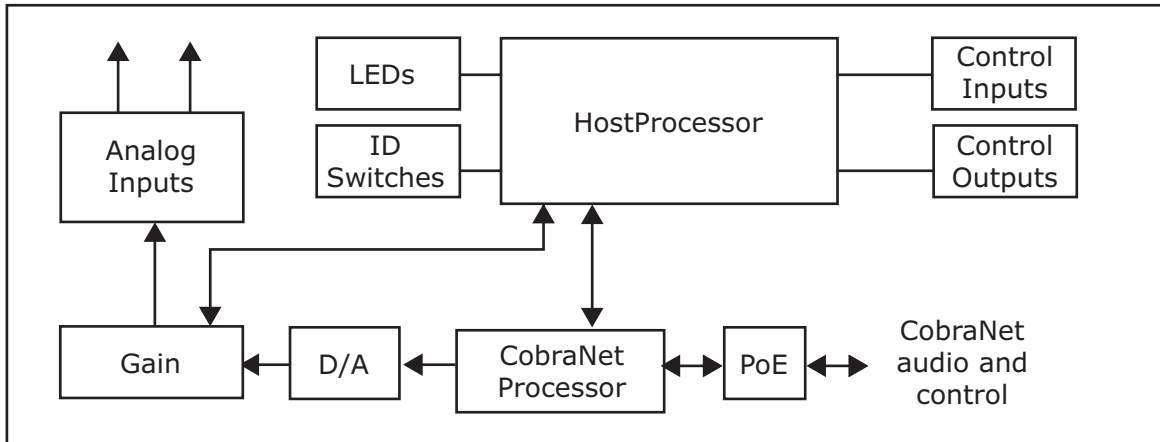

VO-4 WARRANTY

BIAMP SYSTEMS IS PLEASED TO EXTEND THE FOLLOWING 5-YEAR LIMITED WARRANTY TO THE ORIGINAL PURCHASER OF THE PROFESSIONAL SOUND EQUIPMENT DESCRIBED IN THIS MANUAL

1. BIAMP Systems warrants to the original purchaser of new products that the product will be free from defects in material and workmanship for a period of 5 YEARS from the date of purchase from an authorized BIAMP Systems dealer, subject to the terms and conditions set forth below.
2. If you notify BIAMP during the warranty period that a BIAMP Systems product fails to comply with the warranty, BIAMP Systems will repair or replace, at BIAMP Systems' option, the nonconforming product. As a condition to receiving the benefits of this warranty, you must provide BIAMP Systems with documentation that establishes that you were the original purchaser of the products. Such evidence may consist of your sales receipt from an authorized BIAMP Systems dealer. Transportation and insurance charges to and from the BIAMP Systems factory for warranty service shall be your responsibility.
3. This warranty will be VOID if the serial number has been removed or defaced; or if the product has been altered, subjected to damage, abuse or rental usage, repaired by any person not authorized by BIAMP Systems to make repairs; or installed in any manner that does not comply with BIAMP Systems' recommendations.
4. Electro-mechanical fans, electrolytic capacitors, gooseneck microphones, cords connecting handheld microphones, hard-drives, displays, and normal wear and tear of items such as paint, knobs, handles, keypads and covers are not covered under this warranty. All server-based devices are warranted for 3 years only.
5. This warranty is in lieu of all other warranties, expressed or implied. Biamp Systems disclaims all other warranties, expressed or implied, including, but not limited to, implied warranties of merchantability and fitness for a particular purpose.
6. The remedies set forth herein shall be the purchaser's sole and exclusive remedies with respect to any defective product.
7. No agent, employee, distributor or dealer of Biamp Systems is authorized to modify this warranty or to make additional warranties on behalf of Biamp Systems. Statements, representations or warranties made by any dealer do not constitute warranties by Biamp Systems. Biamp Systems shall not be responsible or liable for any statement, representation or warranty made by any dealer or other person.
8. No action for breach of this warranty may be commenced more than one year after the expiration of this warranty.
9. Biamp systems shall not be liable for special, indirect, incidental, or consequential damages, including lost profits or loss of use arising out of the purchase, sale, or use of the products, even if BIAMP Systems was advised of the possibility of such damages.

012012_585.0246.90B

FCC COMPLIANCE

FCC NOTICE - CLASS B DIGITAL DEVICE

NOTE: This equipment has been tested and found to comply with the limits for a Class B digital device, pursuant to Part 15 of the FCC Rules. These limits are designed to provide reasonable protection against harmful interference in a residential as well as in a commercial installation. This equipment generates, uses and can radiate radio frequency energy and, if not installed and used in accordance with the instructions, may cause harmful interference to radio communications. However, there is no guarantee that interference will not occur in a particular installation. If this equipment does cause harmful interference to radio or television reception, which can be determined by turning the equipment off and on, the user is encouraged to try to correct the interference by one or more of the following measures: 1) Reorient or relocate the receiving antenna, 2) Increase the separation between the equipment and receiver, 3) Connect the equipment into an outlet on a circuit different from that to which the receiver is connected or 4) Consult the dealer or an experienced radio/TV technician for help.



EC Declaration of Conformity

Biamp Systems Corporation, as manufacturer having sole responsibility, hereby declares that the following described product complies with the applicable provisions of the DIRECTIVES below except as noted herein. Any alterations to the product not agreed upon and directed by Biamp Systems Corporation will invalidate this declaration.

Product Model: Vocia® VO-4

Product Description: Output Expander for networking with audio DSPs

Applicable EC Directives: Applicable Harmonized Standards:

LVD Directive (2006/95/EC) Safety EN 60065:2002

EMC Directive (2004/108/EC) Emissions EN 55103-1:1996, Environment E2
Immunity EN 55103-2:1996

Special Considerations for Product Environment or Compliance:

Use only CE marked Power over Ethernet (PoE) device.

Use only CE and "LPS" marked 24 VDC External Power Adaptor.

Shielded cabling must be used for system connections.

Technical Construction File, Location and Contact:

Biamp Systems Corporation phone: (503) 641.7287
9300 S.W. Gemini Drive fax: (503) 626.0281
Beaverton, OR USA 97008 e-mail: compliance@biamp.com

Authorized Representative: Larry Copley, Compliance Engineer

Authorized Signature:

Issued: March 2010

COMPLIANCE

EU RoHS COMPLIANT



This Biamp product, including all attendant cables and accessories supplied by Biamp, meets all requirements of EU Directives 2002/95/EC of January 27, 2003, and 2005/618/EC of August 18, 2005, the EU RoHS Directives. An EU RoHS Materials Content Declaration document may be obtained at www.biamp.com

(The following information is presented to comply with the requirements of Chinese law SJ/T11363-2006)

有害物质表 (Hazardous Substances Table)

Biamp Systems Corporation
音频输出设备 (Audio Output Device)
Vocia VO-4

部件名称	有毒有害物质或元素					
	Pb 铅	Hg 汞	Cd 镉	Cr+6 六价铬	PBB	PBDE
设备机箱 (Equipment Chassis)	X	O	X	O	O	O
插拔式接线端子 (Plug-in Terminal Blocks)	O	O	O	O	O	O
光盘(CD ROM)	O	O	O	O	O	O
手册和其他书面文档 (Manual and Documentation)	O	O	O	O	O	O
包装箱和所有包装材料 (Box and Packing Materials)	O	O	O	O	O	O

O: 表示该部件所有均质材料中的这种有毒有害物质低于 SJ/T11363-2006 的限制要求。

X: 表示该部件中至少有一种均质材料所含的这种有毒有害物质高于 SJ/T11363-2006 的限制要求。

在电触头和(或)镀镉所含的均质材料中, 镉及其化合物的含量可以超过 0.01%, 但欧盟指令 91/338/EEC (根据欧盟指令 76/769/EEC) 限制销售和使用某些危险物质和制剂部分中所禁止的用途除外

在以下一种或多种物质所含的均质材料中, 铅及其化合物的含量可以超过 0.1%:

- 1) 电子元器件中玻璃内所含的铅
- 2) 铅在钢材中是作为一种合金元素, 含量可达 0.35%
- 3) 铅在铝材中是作为一种合金元素, 含量可达 0.4%
- 4) 铅在铜材中是作为一种合金元素, 含量可达 4%
- 5) 高熔点类焊料中的铅 (即铅料合金, 铅含量超过 85%)
- 6) 电子陶瓷部件内的铅
- 7) 由两种以上元素组成的焊料中所含的铅, 用于连接引脚和微处理器包装, 其中铅的含量超过 80% 但低于 85%
- 8) 顺应针连接系统内的铅
- 9) 倒装芯片封装中半导体芯片及载体之间形成可靠连接所用焊料中的



在正常使用情况下, 中国环保使用期限为 10 年, 条件是:

- 环境温度为 0-40C (32-104°F)
- 湿度为 0-95%, 无凝结
- 海拔高度为 0-10,000 英尺
- 气流不受阻碍
- 没有水或其他液体进入任何部件
- 电源为 IEEE 802.3af PoE
- 部件没有损坏 (损坏部件应立即修理)
- 由工厂授 ▪ 人 ▪ 使用批准的材料 ▪ 行所有 ▪ 修