

**GENERAL SPECIFICATIONS**

		T5n		T4n		T3n	
		120V(US)	230V(EU)	120V(US)	230V(EU)	120V(US)	230V(EU)
<b>Output Power (W)</b>	2Ω per channel	2500	2500	2200	2200	1900	1900
	4Ω per channel	2200	2350	1950	2050	1400	1400
1kHz	8Ω per channel	1350	1350	1150	1150	790	750
	4Ω bridge	5000	5000	4400	4400	3800	3800
THD+N=1%	8Ω bridge	4400	4700	3900	4100	2800	2800
	2Ω per channel	3400	3400	2900	3100	2200	2150
20mS burst	4Ω bridge	6800	6800	5800	6200	4400	4300
	Constant voltage line	STEREO mode: 100V line, 1250W / 8Ω		-		70.7V line, 625W / 8Ω	
SN ratio	20Hz-20kHz (DIN AUDIO)	107dB		106dB		105dB	
	Power Stand-by			5W			
consumption (W)	Idle			70W			
	1/8*1 (2Ω / Pink noise)	1600W		1400W		1200W	

1/8 = Power consumption at 1/8 maximum output power

<b>All Models</b>		
<b>THD+N</b>	20Hz-20kHz, Half Power RL=4Ω, 8Ω	0.1%
<b>Intermodulation Distortion</b>	60Hz: 7kHz, 4:1, Half Power*2	0.1%
<b>Frequency response</b>	MAX	0dB
	TYP	0dB
	MIN	-0.5dB
<b>Channel Separation</b>	Half Power RL=8Ω, 1kHz Att. max input 600Ω shunt	67dB
<b>Damping Factor</b>	RL=8Ω 1kHz	800
<b>Voltage Gain</b>	Att.max	32dB / 26dB
<b>Maximum Input Voltage</b>		+24dBu*3
<b>Input Impedance</b>		20kΩ (balanced) 10kΩ (unbalanced)
<b>Controls</b>	Front Panel	POWER switch (push on / push off) attenuator (31 position) x 2
	Rear Panel	MODE switch (STEREO / BRIDGE / PARALLEL) x 1 GAIN switch (32dB/26dB) x 1 AMP ID switch (6P DIP) x 1
<b>Connectors</b>	Input	XLR-3-31 type x 2 Euroblock connector (balanced) x 2
	Output	Neutrik® SPEAKON® NL4 x 2, 5-way binding post x 2 pairs
	DATA PORT	RJ45 x 2
<b>Indicators</b>	POWER/STANDBY	x 1 (Green / Orange)
	REMOTE	x 1 (Green)
	PROTECTION	x 1 (Red)
	TEMP	x 1 (Red) heatsink temp ≥ 85°C
	SIGNAL	x 2 (Green)
	MUTE	x 2 (Red)
	CLIP/LIMIT	x 2 (Red)
<b>Load protection</b>		POWER switch on/off mute DC-fault: Amplifier shuts down automatically. clip limiting: THD ≥ 0.5%
	<b>Amplifier protection</b>	thermal: Mute the output (heatsink temp ≥ 90°C) (return automatically.) VI limiter (RL ≤ 1Ω) : Limit the output
	<b>Power supply protection</b>	thermal: Amplifier shuts down automatically. (heatsink temp ≥ 100°C)
<b>Cooling</b>		Continuously variable-speed fan: x 2
<b>Power requirements</b>		US&CANADA: 120V / 60Hz EUROPE: 230V / 50Hz
<b>Dimensions(WxHxD)</b>		480 x 88 x 456mm (2U)
<b>Weight</b>		14.0kg
<b>Accessory</b>		Handle x 2 (with flat-head screw x 4), Euroblock connector x 2, Owner's Manual,

\*1: 1/8 power = 9dB below rated power  
\*2: Half power = 3dB below rated power  
\*3: 0dBu = 0.775Vrms  
Neutrik® and Speakon® are trademarks of Neutrik®.  
All trademarks used are properties of their respective owners.

**Tn Series Dimensions**

unit : mm

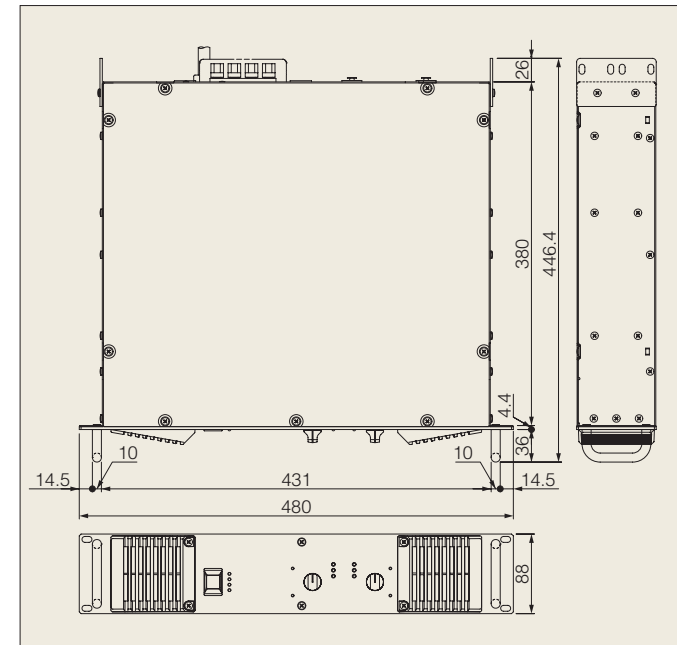

**POWER AMPLIFIER Tn series**



Specifications and appearance are subject to change without notice.

For details please contact:

**YAMAHA**  
YAMAHA CORPORATION  
P.O.BOX 1, Hamamatsu Japan  
<http://www.yamahaproaudio.com>

PRINTED WITH SOYINK This document is printed on chlorine-free (ECF) paper with soy ink.



Printed in Japan

# The New Standard for Large-scale Live Sound

In the 30 years that have passed since the P2200 power amplifier was introduced in 1976, Yamaha has been dedicated to the development of power amps that deliver superior sound, power, and reliability. And now, in 2006, Yamaha is proud to announce a new flagship series that marks this 30th anniversary with unprecedented performance: the Tn Series.

The Tn series amplifiers are ruggedly designed to deliver optimum performance even under tortuous tour conditions, while offering sonic quality befitting a top-line model with up to 2500 watts power output (T5n, stereo @ 2Ω). The ability to stably drive load impedances as low as 2 ohms makes the Tn series amplifiers ideal for powering line-array systems on the road. A high-volume fan cooling system and comprehensive protection circuitry help to maintain high reliability, and power consumption has been reduced by 50% compared to conventional amplifiers thanks to Yamaha's high-efficiency EEEngine amplifier technology. Of course the Tn Series includes on-board networking capability for remote control and monitoring, aptly denoted by the "n" of Tn.

Representing the culmination of 30 years of development and experience, Yamaha new amplifier for Touring with Network capability, the so called Tn series amplifiers are set to become the standard for a new generation of large-scale live sound systems.

## POWER AMPLIFIER T5n / T4n / T3n

Model	Power 2Ω	Power 4Ω	Power 8Ω
T5n	2500W	2350W*	1350W
T4n	2200W	2050W*	1150W
T3n	1900W	1400W	750W

\*230V(EU)



### Main Features

- High power for tour applications: T5n = 2500W, T4n = 2200W, T3n = 1900W.\*
- Extraordinary midrange and high-end detail with solid, commanding bass. Exhaustive vibration-reduction measures have resulted in unprecedented sound quality.
- Stable 2-ohm drive capability is ideal for line array speaker systems.
- A durable exterior, large cooling fans and fan guards, easily replaceable filters, and other reliability features help to deliver total dependability even under demanding tour conditions.
- Original Yamaha EEEngine amp drive technology realizes a 50% reduction in power consumption compared to conventional amplifiers.
- Remote amplifier control and monitoring via the Yamaha ACU-16C Amp Control Unit.
- A variety of input terminals, removable handles, and other features for maximum installation and handling versatility.

\*Stereo, 2Ω.

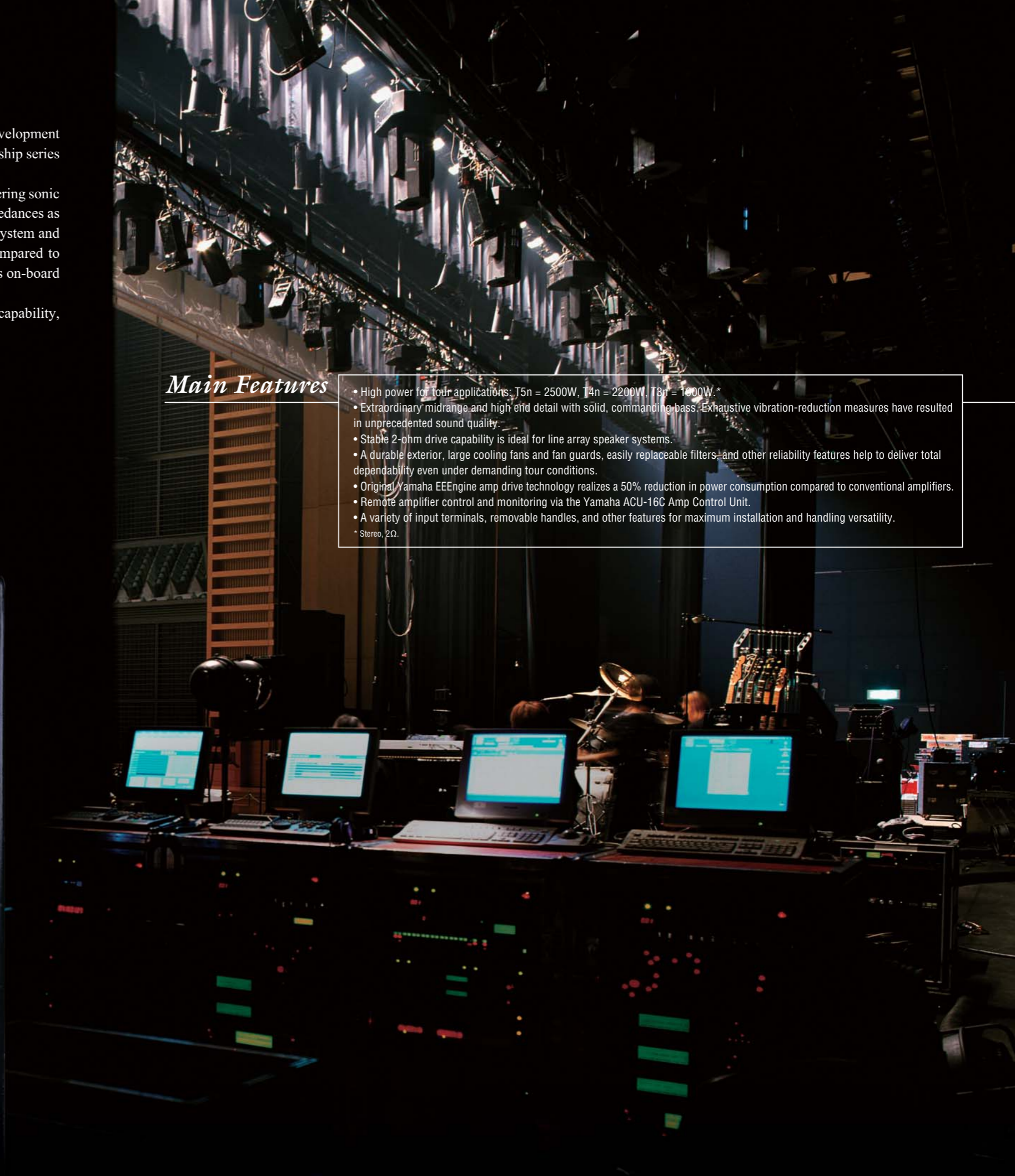

# POWER AMPLIFIER

# T5n / T4n / T3n



T5n REAR PANEL

## T5n internal layout.

- 1 Transformer
- 2 200v Primary tank capacitors
- 3 220v Secondary tank capacitors
- 4 Insulated Gate Bipolar Transistor (for switching power supply)
- 5 Class AB High Quality Amplifier
- 6 High Voltage Thin film Bipolar Transistor
- 7 Thermo Sensor (for Fan Control, Protection, and Status Monitor)

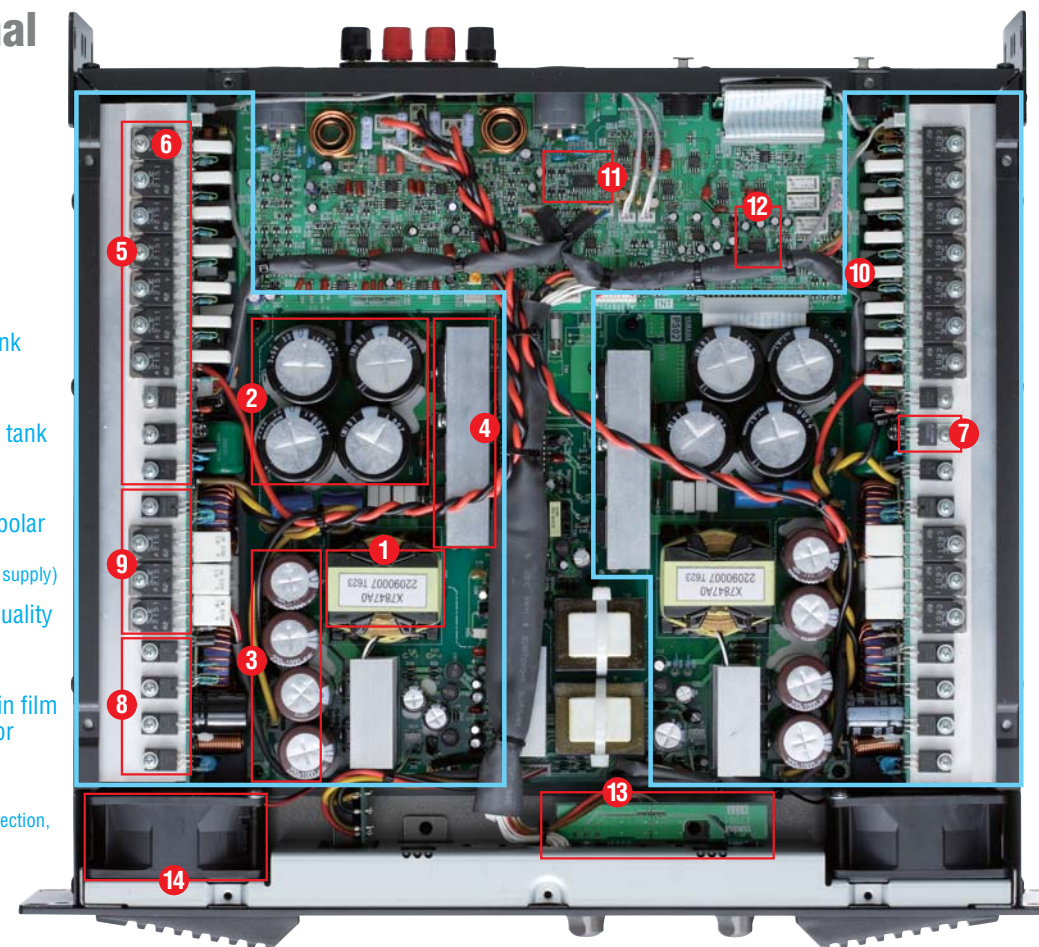

- 8 High-Efficiency Current Buffer for EEEngine
- 9 High-Speed Voltage Buffer for EEEngine
- 10 CPU (for Status Monitor and Remote)
- 11 VCA (for each Limiter)
- 12 Electrical Volume (Custom manufactured by Yamaha)
- 13 High Resolution 1dB Step attenuator
- 14 High Power and High Speed Fan

 : Mono Amp x 2 = Dual Mono Amp structure

## Solid Power for Any Application

In touring applications that require the ability to drive large numbers of speakers, amp drive capability and power become extremely important criteria. Furthermore, since the entire system has to be set up, taken down, and transported for every show, the total number of amps required, and their total weight, has a significant influence on manpower and cost. While the Tn series power amps are all compact 2U-size units, they deliver remarkably high power: 2500 watts from the T5n, 2200 watts from the T4n, and 1900 watts from the T3n, stereo into 2 ohms. Tn series amplifiers are capable of driving line array or other large-scale speaker setups in systems that take up less space than ever before.

### Output Power (W)

	T5n	T4n	T3n
2Ω per channel	2500	2200	1900
4Ω per channel	2350	2050	1400
8Ω per channel	1350	1150	750
4Ω bridge	5000	4400	3800
8Ω bridge	4700	4100	2800

230V(EU), 1kHz, THD+N=1%

## High Definition, Serious Impact



By applying the full gamut of technology, experience, and resources acquired through the development and production of industry-standard digital mixing consoles and signal processors, as well as extensive know-how gained through years of hall and installation system design, The Tn series amplifiers

have been refined to unprecedented levels of performance and sound quality. Transparency across the entire audio spectrum is a basic requirement, but the Tn amplifiers go beyond the basics with extraordinary midrange presence and a low end that is huge and authoritative while maintaining maximum reproduction accuracy. This has been achieved not only through no-compromise parts selection and circuit design, but also through extensive vibration-reduction measures that effectively suppress internal vibration that can have a negative impact on sound quality. The heat sinks, for example, are solidly screwed to the chassis side panels at numerous points, but with special insulators that are designed to absorb vibration and chassis resonance that would otherwise interfere with optimum reproduction. The detailed work involved goes well beyond the normal definition of manufacturing and crosses over into the realm of craftsmanship.



## Stable 2-ohm Drive Capability

Line array systems offer many benefits for large scale live sound applications, but because of the many speakers involved they normally need to be driven by a correspondingly large number of power amplifiers. The 2-ohm drive capability of the Tn series amplifiers easily drives multiple speakers in line array systems. And also Tn series is an excellent choice for driving multiple parallel-connected Yamaha Installation Series speakers as well as multiple parallel-connected monitor speakers allocated on the stage. In order to provide stable low-impedance drive capability the Tn amplifiers employ newly developed thin-film power transistors, and flat-wire power transformer windings to minimize heat loss. Many other details contribute, but the final result is totally stable drive capability down to 2 ohms.

## Durability to Handle the Most Demanding Tours

Daily setup, take down, and transportation is an unavoidable part of the touring routine, and the Tn series amplifiers are built to take it all in their stride. A durable exterior resists dents and breakage, while dual high-volume cooling fans maintain stable operation under a wide range of ambient conditions. Large, tough fan guards prevent damage during transportation. Fan speed is automatically varied according to the current output power to minimize noise and maximize motor life. Dust filters at the fan intakes can be easily removed for cleaning. A comprehensive range of protection circuits is also provided: DC, muting, thermal protection, and an advanced output short sensing circuit (PC limiting) that contributes to reliable low-impedance drive

capability. There's also a VHF protection circuit that will prevent damage to HF speaker units if input signals with frequencies higher than 20 kHz continue for more than a few seconds. All in all the Tn series amplifiers offer failsafe performance that will keep the show running night after night under even the severest conditions.



## Ultra-efficient Yamaha EEEngine Amp Drive



Original Yamaha EEEngine technology reduces power consumption by approximately 50% compared to conventional amplifiers. Power supply quality and capacity are perennial obstacles in large-scale live sound systems, but the Tn series amplifiers' high power output with dramatically reduced power consumption goes a long way towards alleviating the problem. Reduced power consumption simultaneously achieves reduced heat generation, significantly increasing part life and reliability. Reduced heat generation further means that smaller, less-obtrusive cooling fans can be used, providing greater freedom for internal layout. That, in turn, translates into overall design that emphasizes sound quality rather than simply keeping the amp stable. In order to achieve stable 2-ohm drive capability the EEEngine circuitry in the Tn series amplifiers features a newly developed high-efficiency FET current buffer drive circuit. Only Yamaha can deliver this level of high efficiency and stability with low-impedance loads.

POWER AMPLIFIER  
T5n / T4n / T3n

Advanced Networking Capability

The rear panels of the Tn series power amplifiers feature RJ45 connectors that allow connection to a Yamaha ACU-16C Amp Control Unit for remote status monitoring and control of parameters such as on/off switching, muting, and attenuation from a computer. Furthermore, warnings can be displayed when preset parameter limits are exceeded, and automatic logging contributes to easy, efficient troubleshooting. With an NHB32-C Network Hub/Bridge it also becomes possible to remotely control multiple units via a CobraNet™ network. In addition to the ACU-16C's amp control features, it can also function as a high-precision 16-channel DA converter, receiving 24-bit digital audio data over a CobraNet™ network.

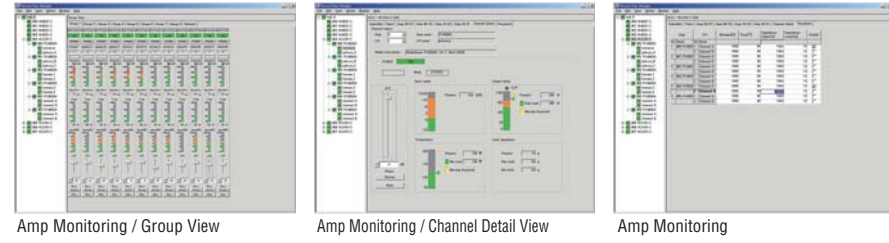

**AMP CONTROL UNIT ACU16-C** The amp control unit featuring Tn series control and monitoring capabilities plus CobraNet™ compatibility.



**NETWORK HUB / BRIDGE NHB32-C** The network hub/bridge for CobraNet™ networking with up to 32-channel digital audio and control signal reception/transmission capabilities.



System Example

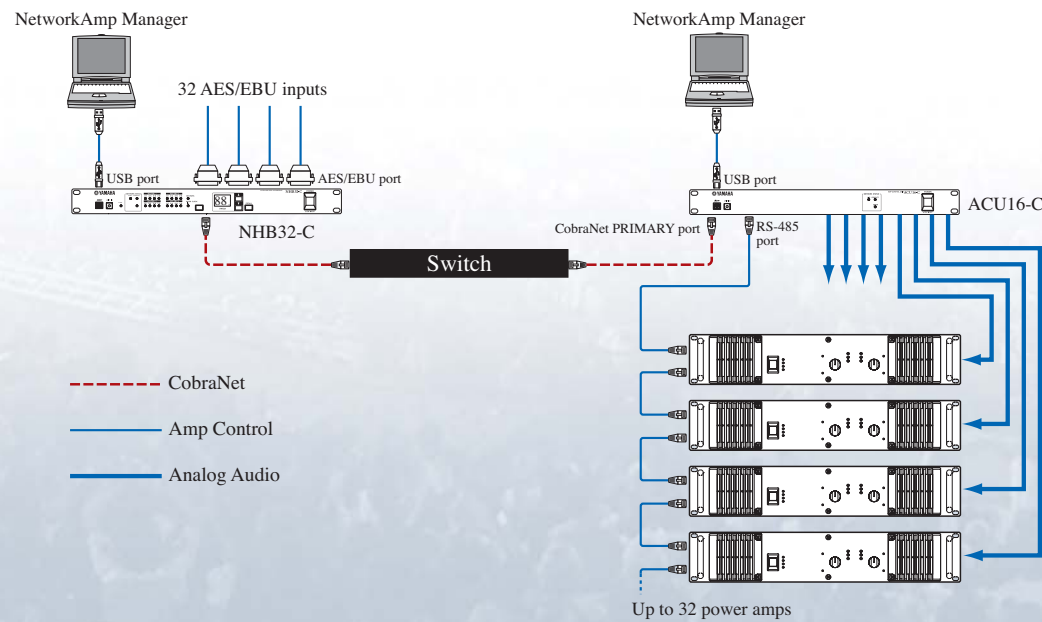

Monitoring and control of multiple amplifiers with NetworkAmp Manager

- The ACU16-C amplifier control unit and a PC running NetworkAmp Manager can monitor/control the operating conditions of up to 32 amplifiers, including power, attenuation, inputs, outputs, temperature and load impedance.
- A PC running NetworkAmp Manager can be connected not only to an ACU16-C via a USB port, but also to an NHB32-C network hub/bridge on the CobraNet™ network. This versatility gives you full remote amp control capability — for dramatically improved operating efficiency.
- Using CobraNet™, the ACU16-C's D/A conversion function can convert up to 16 channels of digital audio signals to high-quality analog audio signals.
- One CobraNet™ network can be used to connect up to 8 NHB32-C units and 16 ACU16-C units — giving you the freedom to configure large-scale audio networks.

Superior Handling through Extensive Experience In the Field

The Tn series power amplifiers represent the culmination of over 30 years of know-how acquired through amp development and manufacture as well as feedback from professionals in the field. Details can make a huge difference in real-world handling ... such as detachable front-panel handles to meet the needs of various situations. Also, Euroblock connectors are provided in addition to XLR connectors for full compatibility with installation wiring. The Euroblocks can also be used as link out connectors for flexible integration with the widest possible range of system needs.



EEngine delivers incredible power while preserving sound quality  
Combines highly efficient driving function with tremendous power conservation

State of the Art: YAMAHA EEngine Evolution with supporting 2-ohm drive

EEngine overcomes the problem existed in the conventional power amplifier system while providing advantages in all areas, offering a dramatic leap in power amplifier design. It realizes efficiency that matches Class D without compromising the sound quality of a Class AB amplifier. Furthermore, EEngine solves all of the problems of weight, size, and heat generation that users of large-output power amplifiers often encounter. Additionally new Tn series amplifiers has the evolution comparing to the PC-1N series by having stable 2-ohm drive capability thank to the new developed high efficiency electrical current buffer FET drive circuit.

EEngine tracks the audio signal to always provide the minimum power needed for the final output stage, allowing for surprising improvement in efficiency. It utilizes Class D operation to provide the power at the final output stage of Class AB operation. Almost all of the current energy is outputted as the audio signal, and just a small fraction of the remaining energy is emitted as heat dissipation through the heat sink.

With the final output stage operating at Class AB, the output signal is of remarkably high sound quality. The signal remains analog from input to output, without being converted to a PWM signal. There is none of the deterioration of frequency response and damping factor found with Class D systems. Plus, EEngine is designed to operate perfectly while keeping the power amplifier heat generation to a minimum, regardless of the load requirements. All together, you get Class AB sound quality with efficiency that matches Class D.

Figure 1: EEngine operational waveform

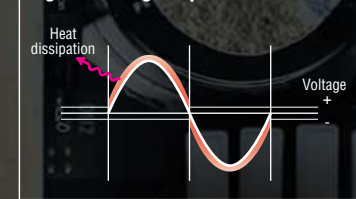
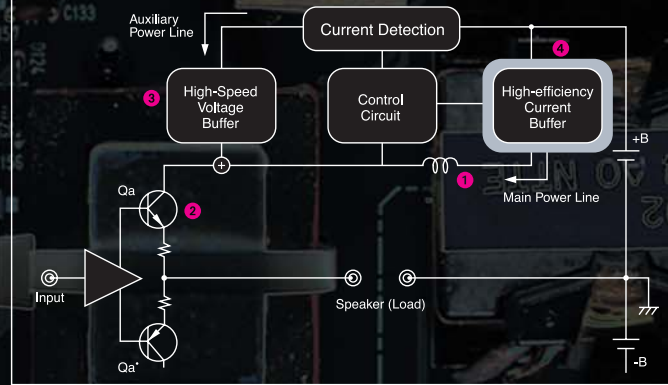

Figure 2: EEngine technology block diagram



- A main power supply line that supplies driving power to the speaker
- A high-efficiency current buffer combining a switching element that switches the main power supply line on and off with a leveling circuit
- A control circuit that varies the on/off switching frequency according to the input signal level
- An auxiliary power line that supplies power independent of the main power supply in quick response to the input signal level
- A high-speed voltage buffer and current detector that adjust and control the auxiliary power supply level  
This arrangement ensures efficient and highly accurate power amplification even when input signal amplitude rises steeply

Keeps up with sharp increases in sound

EEngine's auxiliary power supply works with the main power supply to always drive at just the right power current to obtain maximum output, providing a high following capability even when there are steep increases in sound. This reduces power consumption while maintaining the special features of a "fast amp." Plus, even when driving the fast auxiliary power supply in this method at ample voltage, power provided from the main power supply unit is very efficient at normal times, reducing the average current value and dramatically improving power loss.

Figure 3: Efficiency comparison data (power consumption vs. output)

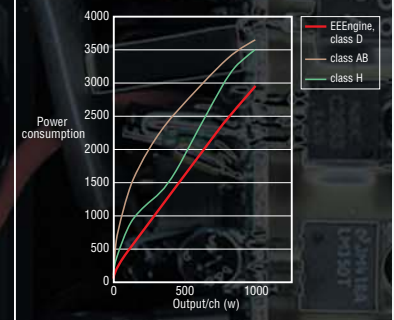

Improved parts life and reliability

In addition to its tremendous improvements in efficiency and preservation of great sound quality, EEngine plays yet another important role. It is often said that a power amplifier's parts will last twice as long if the internal temperature is reduced by 10 degrees Celsius. EEngine's heat generation during usage is 35% less than previous systems, contributing greatly to improvements in durability and reliability.

Figure 4: Efficiency comparison data (heat generation level vs. output)

