

DPA-Q Series Amplifiers



User Manual

DPA8.4Q — 8 Channel, 4000 W Network Amplifier with Mic/Line Inputs

DPA8.8Q — 8 Channel, 8000 W Network Amplifier with Mic/Line Inputs

DPA8.4Qn — 8 Channel, 4000 W Network Amplifier

DPA8.8Qn — 8 Channel, 8000 W Network Amplifier

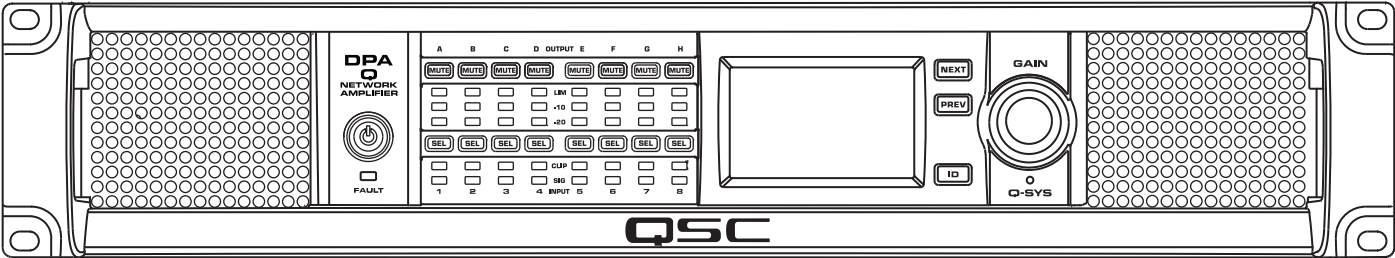

TD-001523-01-A



EXPLANATION OF SYMBOLS

The term **“WARNING!”** indicates instructions regarding personal safety. If the instructions are not followed the result may be bodily injury or death.

The term **“CAUTION!”** indicates instructions regarding possible damage to physical equipment. If these instructions are not followed, it may result in damage to the equipment that may not be covered under the warranty.

The term **“IMPORTANT!”** indicates instructions or information that are vital to the successful completion of the procedure.

The term **"NOTE"** is used to indicate additional useful information.



The intent of the lightning flash with arrowhead symbol in a triangle is to alert the user to the presence of un-insulated "dangerous" voltage within the product's enclosure that may be of sufficient magnitude to constitute a risk of electric shock to humans.



The intent of the exclamation point within an equilateral triangle is to alert the user to the presence of important safety, and operating and maintenance instructions in this manual.



IMPORTANT SAFETY INSTRUCTIONS



WARNING!: TO PREVENT FIRE OR ELECTRIC SHOCK, DO NOT EXPOSE THIS EQUIPMENT TO RAIN OR MOISTURE.

1. Read these instructions.
2. Keep these instructions.
3. Heed all warnings.
4. Follow all instructions.
5. Do not use this apparatus near water.
6. Clean only with a dry cloth.
7. Do not block any ventilation opening. Install in accordance with the manufacturer's instructions.
8. Do not install near any heat sources such as radiators, heat registers, stoves, or other apparatus that produce heat.
9. To reduce the risk of electrical shock, the power cord shall be connected to a mains socket outlet with a protective earthing connection.
10. Do not defeat the safety purpose of the polarized or grounding-type plug. A polarized plug has two blades with one wider than the other. A grounding type plug has two blades and a third grounding prong. The wide blade or the third prong are provided for your safety. If the provided plug does not fit into your outlet, consult an electrician for replacement of the obsolete outlet.
11. Protect the power cord from being walked on or pinched particularly at plugs, convenience receptacles, and the point where they exit from the apparatus.
12. Only use attachments/accessories specified by the manufacturer.
13. Unplug this apparatus during lightning storms or when unused for long periods of time.
14. Refer all servicing to qualified service personnel. Servicing is required when the apparatus has been damaged in any way, such as power-supply cord or plug is damaged, liquid has been spilled or objects have fallen into the apparatus, the apparatus has been exposed to rain or moisture, does not operate normally, or has been dropped.
15. The appliance coupler, or the AC Mains plug, is the AC mains disconnect device and shall remain readily operable after installation. On units equipped with powerCon® connectors, the AC Mains disconnect device is the AC Mains plug only; do not use the appliance coupler.
16. Adhere to all applicable, local codes.
17. Consult a licensed, professional engineer when any doubt or questions arise regarding a physical equipment installation.
18. Do not use any aerosol spray, cleaner, disinfectant or fumigant on, near or into the apparatus. Clean only with a dry cloth.
19. Do not unplug the unit by pulling on the cord, use the plug.
20. Do not submerge the apparatus in water or liquids.
21. Keep ventilation opening free of dust or other matter.

Maintenance and Repair



WARNING!: Advanced technology, e.g., the use of modern materials and powerful electronics, requires specially adapted maintenance and repair methods. To avoid a danger of subsequent damage to the apparatus, injuries to persons and/or the creation of additional safety hazards, all maintenance or repair work on the apparatus should be performed only by a QSC authorized service station or an authorized QSC International Distributor. QSC is not responsible for any injury, harm or related damages arising from any failure of the customer, owner or user of the apparatus to facilitate those repairs.

FCC Statement



NOTE: This equipment has been tested and found to comply with the limits for a Class B digital device, pursuant to Part 15 of the FCC Rules.

These limits are designed to provide reasonable protection against harmful interference in a residential installation. This equipment generates, uses and can radiate radio frequency energy and, if not installed and used in accordance with the instructions, may cause harmful interference to radio communications. However, there is no guarantee that interference will not occur in a particular installation. If this equipment does cause harmful interference to radio or television reception, which can be determined by turning the equipment off and on, the user is encouraged to try to correct the interference by one or more of the following measures:

- Reorient or relocate the receiving antenna.
- Increase the separation between the equipment and receiver.
- Connect the equipment into an outlet on a circuit different from that to which the receiver is connected.
- Consult the dealer or an experienced radio/TV technician for help.

RoHS STATEMENT

The QSC DPA8.4Q, DPA8.4Qn, DPA8.8Q and DPA8.8Qn amplifiers are in compliance with European Directive 2011/65/EU – Restriction of Hazardous Substances (RoHS2).

The QSC DPA8.4Q, DPA8.4Qn, DPA8.8Q and DPA8.8Qn amplifiers are in compliance with “China RoHS” directives. The following chart is provided for product use in China and its territories:

QSC DPA8.4Q, DPA8.4Qn, DPA8.8Q and DPA8.8Qn Amplifiers						
部件名称 (Part Name)	有毒有害物质或元素 (Toxic or hazardous Substances and Elements)					
	铅 (Pb)	汞 (Hg)	镉 (Cd)	六价铬 (Cr(vi))	多溴联苯 (PBB)	多溴二苯醚 (PBDE)
电路板组件 (PCB Assemblies)	X	O	O	O	O	O
机壳装配件 (Chassis Assemblies)	X	O	O	O	O	O

O: 表明这些有毒或有害物质在部件使用的同类材料中的含量是在 SJ/T11363_2006 极限的要求之下。
(O: Indicates that this toxic or hazardous substance contained in all of the homogeneous materials for this part is below the limit requirement in SJ/T11363_2006.)

X: 表明这些有毒或有害物质在部件使用的同类材料中至少有一种含量是在 SJ/T11363_2006 极限的要求之上。
(X: Indicates that this toxic or hazardous substance contained in at least one of the homogeneous materials used for this part is above the limit requirement in SJ/T11363_2006.)

Warranty

For a copy of the QSC Limited Warranty, visit the QSC website at www.qsc.com

Unpacking

There are no special unpacking instructions. You may want to keep the shipping material for the unlikely event that the amplifier should need returning for service.

Package Contents

- Quick-Start Guide TD-000476
- Safety Sheet TD-000420
- Amplifier
- Power Cord
- Euro-style Connector Plug, 3-pin (8) (DPA8.4Q and DPA8.8Q only)
- Euro-style Connector Plug, 8-pin (2)
- Euro-style Connector Plug, 3.5 mm, 16-pin (1)

Features

Amplifier Front Panel

Refer to "Amplifier Controls and Indicators" on page 8.

Amplifier Rear Panel

Refer to Figure 1 (DPA8.4Q / DPA8.8Q shown)



NOTE: The DPA8.4Qn and DPA8.8Qn models do not have the analog inputs (Item 3 below).

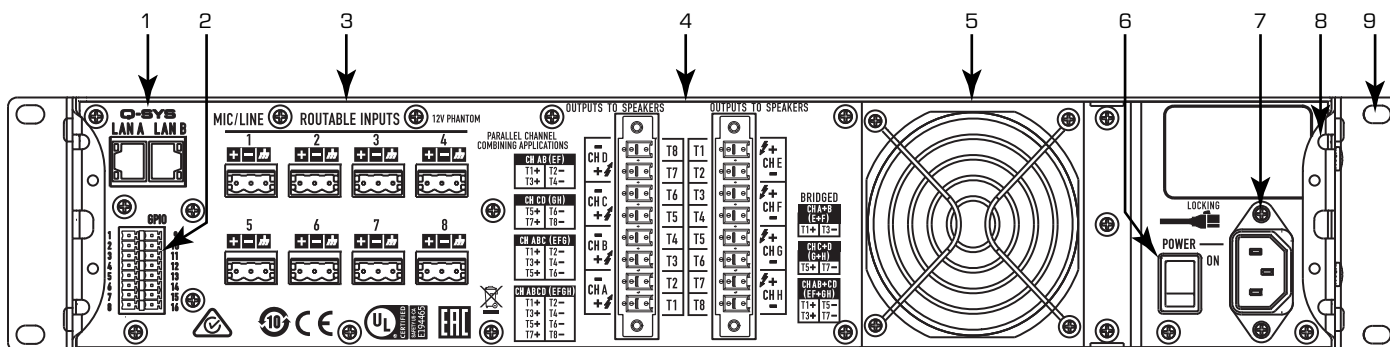

— Figure 1 —

1. RJ-45 Q-SYS Q-LAN A/B
2. GPIO Euro-style Connector, 16-pin
3. Analog Inputs (1-8) – Eight 3-pin Euro-style Connectors (Only DPA8.4Q and DPA8.8Q models.)
4. Outputs (A-H) – Two 8-pin Euro-style Loudspeaker Connector
5. Cooling fan inlet (do not block)
6. AC Power Switch
7. Locking IEC Power Connection
8. Rear Rack-mount Bracket
9. Front Rack-mount Brackets

Installation

The following steps are written in the recommended installation order.

Rack-Mount the Amplifier

The DPA-Q Series amplifiers are designed to be mounted in a standard rack-mount unit. The amplifiers are 2RU high, and 381 mm (15 in) deep.

1. Secure the amplifier in the rack with eight screws (not supplied), four in front, four in back. For complete instructions, refer to TD-000050 "Rear Rack Ears Installation Guide" which can be found on the QSC Website (www.qsc.com)



CAUTION: Be sure that nothing is blocking the front or rear ventilation openings, and that each side has a minimum of 2 cm clearance.

Inputs

Connect the amplifier LAN A, and if available, LAN B, to the Q-LAN network (Figure 4). Refer to your Q-SYS documentation for network requirements and connection detail.

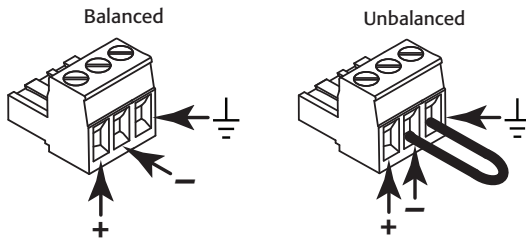

— Figure 2 —

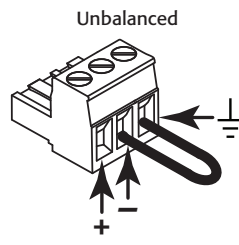

— Figure 3 —

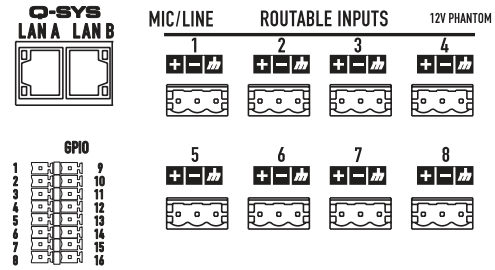

— Figure 4 —

The analog inputs are converted to digital audio in the DPA8.4Q and DPA8.8Q amplifiers and then routed to the Q-SYS Core over the network. The digital signals show up in Q-SYS Designer at the DPA-Q input component where they can be routed as needed. Refer to the Q-SYS documentation.

1. Make sure your audio source devices are powered off.
2. Wire the audio mic- or line-level source to up to eight Euro-style connectors (supplied), you can use either balanced inputs (Figure 2) or unbalanced inputs (Figure 3).
3. Plug the connectors into the appropriate receptacles (Routable Inputs 1, 2, 3, 4, 5, 6, 7, 8) Figure 4 and Figure 5.

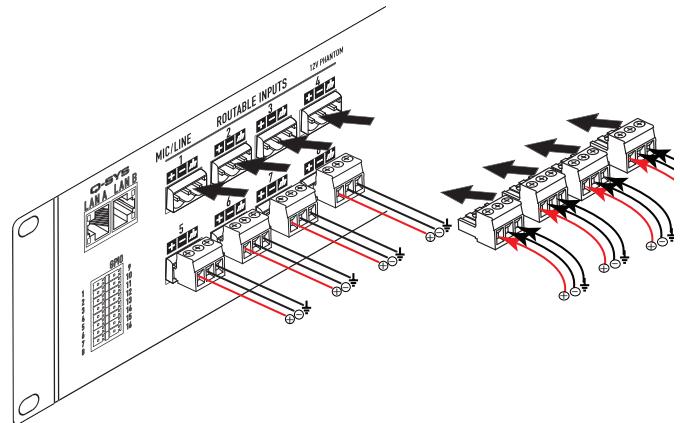

— Figure 5 —

GPIO

Refer to "GPIO" on page 13 for details about the GPIO feature.

Outputs and Output Configuration

The DPA-Q amplifiers have two sets of four-channel outputs that are configured independently. The configuration of the amplifier is defined in Q-SYS designer software and is "pushed" into the physical amplifier when the Name and Type of amplifier in the design matches the Name and Type of physical amplifier. When the output configuration of the amplifier changes, the Outputs to the loudspeakers change accordingly.

Use the diagrams shown in Figure 6 thru Figure 9 as a reference for planning your loudspeaker configuration. Refer to Figure 10 for how to connect the wiring based on your configuration. After connecting the loudspeakers to the outputs, you may turn the amplifier on.



CAUTION! Before turning the amplifier on, double check your output connections to be sure they are connected properly based on the output configuration specified in Q-SYS Designer.

If you change the output configuration of the amplifier you must change the loudspeaker connections before applying power to the amplifier!

After a change of the output configuration, the amplifier re-boots and all outputs are muted. You must press the Mute All button in the Q-SYS Amp Output component, or unmute all channels on the front panel of the amplifier.

Figure 6 thru Figure 9 are examples of the three types of output configurations: Separate, Bridged and Parallel. The tables to the right and left of the loudspeaker connections (rear panel of the amplifier) give all the possible configurations and their connections.

Separate Channels (A B C D) and (E F G H)

For Separate Loudspeakers

Use eight 2-wire cables, connect to:

- T1+/T2- (Loudspeaker A / E)
- T3+/T4- (Loudspeaker B / F)
- T5+/T6- (Loudspeaker C / G)
- T7+/T8- (Loudspeaker D / H)

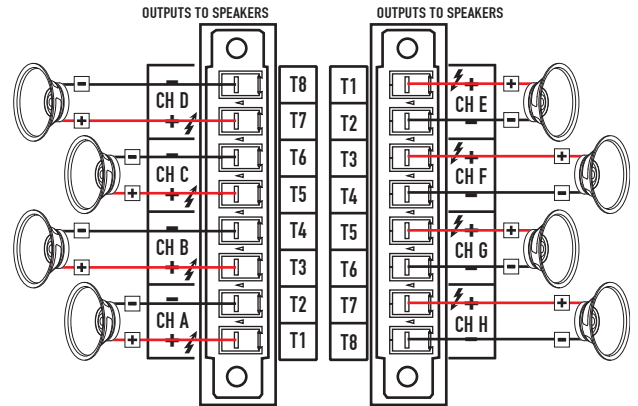
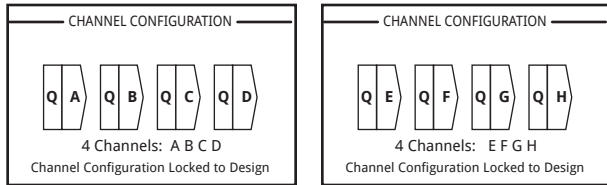

— Figure 6 —

Bridged (A+B) and Separate (C D) and (E F G H) Channels

For A+B (Bridged) One Loudspeaker

Use one 2-wire cable connect to:

- T1+/T3- (Loudspeaker A+B)

For C D (E F G H) (Separate) Two and Four Loudspeakers

Use six 2-wire cables, connect to:

- T1+/T2- (Loudspeaker E)
- T3+/T4- (Loudspeaker F)
- T5+/T6- (Loudspeaker C / G)
- T7+/T8- (Loudspeaker D / H)

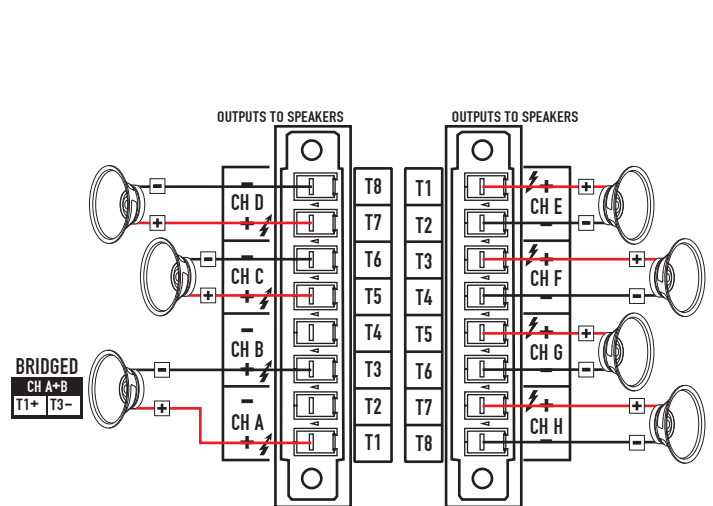
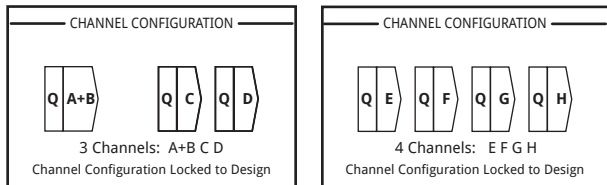

— Figure 7 —

Two Pair of Parallel Channels (AB CD) and two Pair of Parallel Channels Bridged (EF + GH)

AB (Parallel) CD (Parallel) For Two Loudspeakers

Use two 2-wire cables, connect to:

- T1+/T2- (Loudspeaker AB)
- T5+/T6- (Loudspeaker CD)

EF (Parallel) Bridged with GH (Parallel) For One Loudspeaker

Full power to one loudspeaker

Use one 2-wire cable, connect to:

- T1+/T5- (Loudspeaker EF+GH)

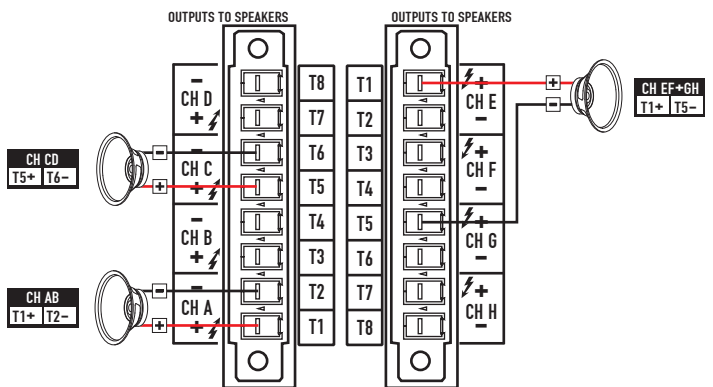
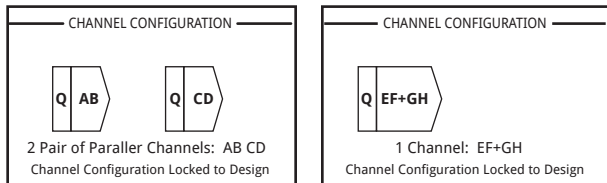

— Figure 8 —

Parallel Channels (ABCD) and (E F G H)

For One Loudspeaker

Full power to one loudspeaker; Use one 2-wire cable, connect to:

- T3+/T4- (Loudspeaker ABCD)

For Multiple Loudspeakers

Full power for multiple loudspeakers in parallel Use up to four 2-wire cables, connect to:

- T1+/T2- (Loudspeaker E)
- T3+/T4- (Loudspeaker F)
- T5+/T6- (Loudspeaker G)
- T7+/T8- (Loudspeaker H)

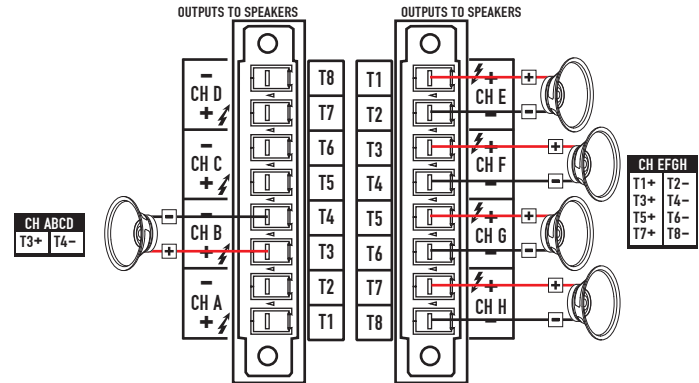
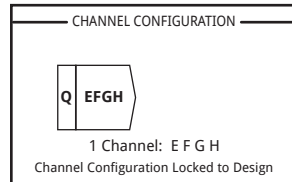
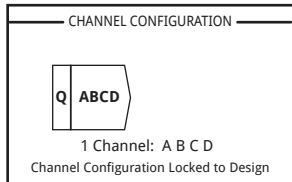

In 4-1 Parallel (ABCD or EFGH) only
T1+, T3+, T5+, and T7+ are electrically the same point
T2-, T4-, T6-, and T8- are electrically the same point

— Figure 9 —

Connect the Loudspeakers

1. Connect the loudspeaker wiring to the 8-pin Euro-style connector as needed for your amplifier's configuration.
2. Install the female 8-pin Euro-style connector onto the male connector on the rear of the amplifier as shown in Figure 10.
3. Use a Phillips screwdriver to secure the connector.

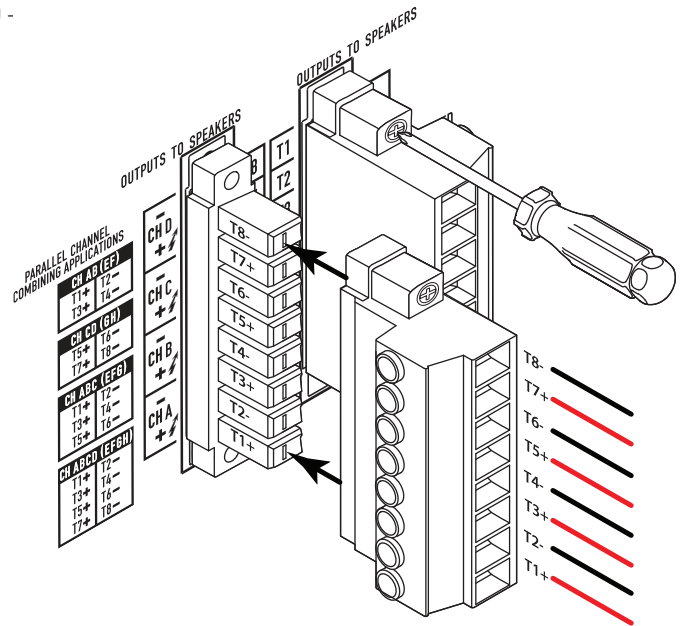

— Figure 10 —

AC Mains



WARNING!: When the AC Power is on, there is a potential of having dangerous voltage at the output terminals on the rear of the amplifier. Use caution not to touch these contacts. Turn off the AC Mains disconnect switch prior to making any connections.

1. Make sure the power switch on the rear of the amplifier is off.
2. Connect the IEC power cord to the AC receptacle. (Figure 11)

AC Power On

After connecting the outputs to the loudspeakers, you may turn the amplifier on.

1. Make sure the output gain settings for all audio-source devices (CD Players, Mixers, Instruments, etc.) are at the lowest output (max attenuation).
2. Turn on all audio sources.
3. Turn the AC Mains power switch on the back of the amplifier to ON. The amplifier starts in the state it was in when power was removed. If the amplifier is in Standby or Mute All mode (Power button LED solid red or blinking), press the Power button to change the amplifier to Run mode.
4. You can now bring up the outputs of your audio sources.

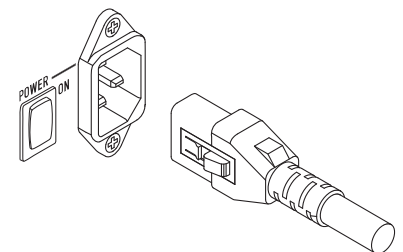

— Figure 11 —

Amplifier Controls and Indicators

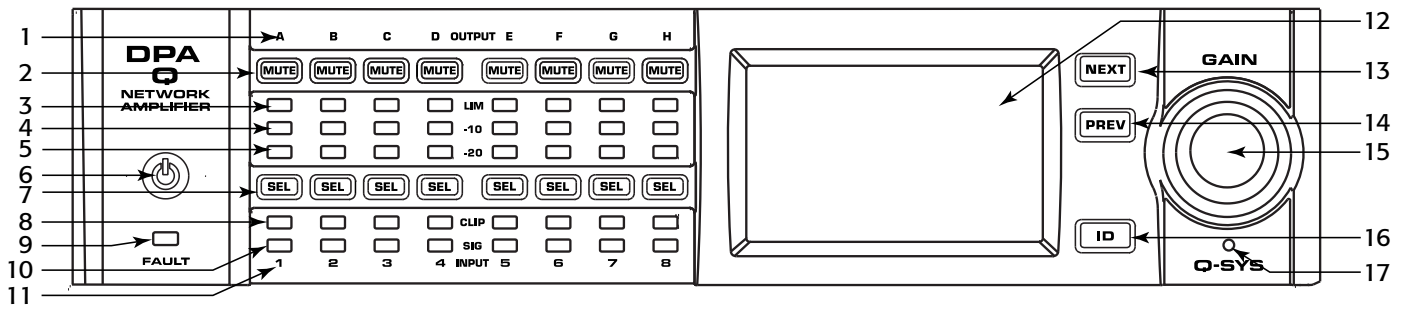

— Figure 12 —

- | | | |
|--|---|-------------------------|
| 1. Output Channel labels A, B, C, D, E, F, G, H | 6. Front-panel Power Button (Green/Red) | 12. LCD Graphic Display |
| 2. Output Channel Mute Buttons / LEDs (Red) | 7. Output Channel Select Buttons / LEDs (Blue) | 13. NEXT Button |
| 3. Output Channel Limiter LEDs (Red) | 8. Input Channel Clip LEDs (Red) | 14. PREV Button |
| 4. Output Channel -10 dB below maximum amplifier output (Blue) | 9. FAULT LED (Amber) | 15. MASTER CONTROL Knob |
| 5. Output Channel -20 dB below maximum amplifier output (Blue) | 10. Input Channel Signal-Present LEDs (Blue) | 16. ID Button |
| | 11. Input Channel labels 1, 2, 3, 4, 5, 6, 7, 8 | 17. Pinhole Reset |



NOTE: The following scenarios assume that the amplifier is connected to the Q-SYS Core via Q-LAN. *When the amplifier is not connected to the Q-SYS Core, it is in a Fault mode, and not operational unless previously configured for fail-over or standalone mode as part of a Q-SYS design.* With the exception of the Power Switch, found on the rear panel, all of the following controls are on the front panel.

Refer to Figure 12 for location of front-panel controls.

Amplifier Modes

Off Mode

- Rear-panel power switch is off, the amplifier is not operable. **The power switch is the AC Mains disconnect.**
- The front-panel power button (6) is not illuminated.
- Turn the power switch to ON. The amplifier enters the mode in which it was when power was removed – Run, Mute All, or Standby.



Run Mode

- From Standby or Mute All mode, press and release the power button on the front panel. The amplifier is in Run Mode.
- The power button (6) is illuminated green.
- The amplifier is fully operable; audio can pass.



Standby Mode

- From Mute All or Run mode, press and hold the power button (6) on the front panel for approximately four seconds.
- The power button illuminates solid red.
- The amplifier is not operable; audio will not pass.



Mute All Mode

- From the Run Mode, quickly press and release the power button (6).
- The power button flashes red, all output Mute buttons (2) are red.
- The amplifier output is disabled, but the front panel is fully operable.



Controls

SEL Buttons (7)



- Channel gain can be adjusted from the Q-SYS Designer software or from the front panel of the amplifier.
- Use the SEL button to select one or more than one channel to change gain settings. All selected channels will change at the same time.
- If two or more outputs are bridged or in parallel, pressing one button in the group selects all channels in that bridged or parallel group.

NEXT (13) and PREV (14) Buttons



- Navigates forward and backwards through the screens.

Master Control Knob (15)



- Adjusts the Gain for the selected channel or channels. At least one channel must be selected.
- When one or more channels are selected, turn the Master Control knob to jump to the Gain screen. After a few seconds with no activity, it returns to the earlier screen.
- If there is more than one channel selected, and the gains for those channels are different, the difference is maintained unless the gain is raised or lowered to the limits for both channels.

ID Button (16)



- Press this button to display a screen with the amplifier's network name. In addition, the ID buttons on the associated Q-SYS Amplifier component and the associated Q-SYS Configurator item flashes. Press again, or click one of the other ID buttons, to stop the flashing and exit the screen.

Pinhole Reset (17)



- Insert a paper clip or similar tool into the pinhole, press and hold for 3 sec. then press the ID button to confirm and reset the amplifier. Default settings include network settings to Auto, Amplifier Name, password, and log file.

Input and Output Signal Flow

DPA8.4Q and DPA8.8Q

Refer to Figure 13

The DPA8.4Q and DPA8.8Q amplifiers have eight MIC/LINE inputs and eight (two blocks of four) amplified outputs on the rear of the amplifier. The inputs and outputs are not physically (or electrically) connected in the amplifier giving you the flexibility to use any available source in Q-SYS for the amplified outputs, and to route the inputs to any output. The inputs and outputs can be connected in your Q-SYS design as shown in Figure 13.

1. The analog inputs are converted to digital audio in the amplifier
2. The converted audio is then routed to the Q-SYS Core via Q-LAN (LAN A, LAN B).
3. The digital signals are brought into the design via the amplifier's Mic/Line Input component.
4. From the Mic/Line Input component the signals can be sent for processing and can be sent anywhere within the Q-SYS system.
5. In the Q-SYS Core digital audio signals (not necessarily from the amp's inputs) are sent to the Q-SYS Amp Output component.
6. The digital audio is then sent from the Q-SYS Core via Q-LAN to the amplifier.
7. Digital signals are converted to analog, amplified and sent to outputs of the amplifier.

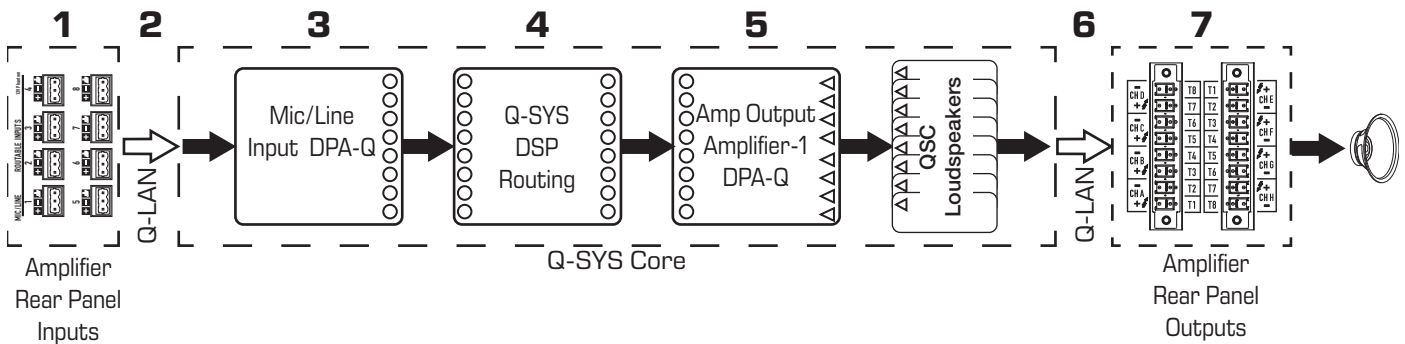

— Figure 13 —

The Q-SYS Amp Output component can have two to eight inputs/outputs depending on the configuration of the amplifier in Q-SYS Designer. The desired configuration is selected in the Q-SYS Designer Properties menu for the amplifier. When the amplifier's configuration is changed, all of the outputs are placed in a "mute all" state. You must un-mute all in the Amp Output component's control panel or on the amplifier's front panel.

DPA8.4Qn and DPA8.8Qn

Refer to Figure 14

The DPA-Qn model amplifiers have no analog inputs. The input signal utilized to drive the amplifier channels must be virtually wired in Q-SYS Designer. The DPA-Qn models have eight (two blocks of four) amplified outputs on the rear of the amplifier.

1. Digital audio is sent to the Q-SYS Core via Q-LAN (LAN A, LAN B).
2. In the Core, the signals can be sent for processing and can be sent anywhere within the Q-SYS system.
3. In the Q-SYS Core digital audio signals are sent to the Q-SYS Amp Output component.
4. The digital audio is then sent from the Q-SYS Core via Q-LAN to the amplifier.
5. Digital signals are converted to analog, amplified, and sent to the outputs of the amplifier.

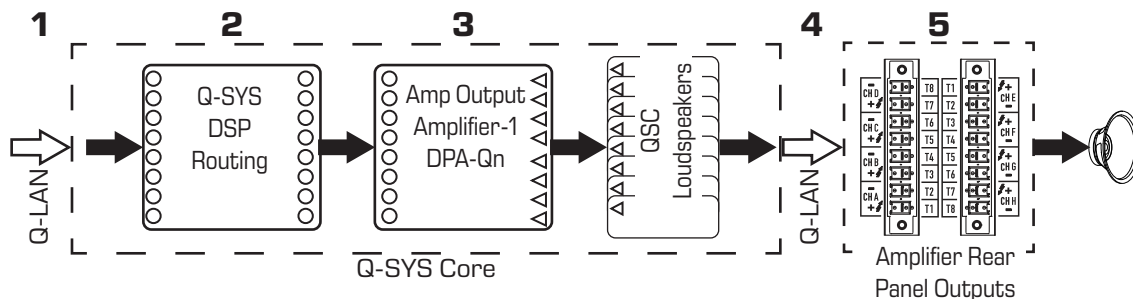

— Figure 14 —

The Amp Output component can have two to eight outputs depending on the configuration of the amplifier in Q-SYS Designer. The desired configuration is selected in the Q-SYS Designer Properties menu for the amplifier. When the amplifier's output configuration is changed, all of the outputs are placed in a "mute all" state. You must unmute all in the Amp Output component's control panel or on the amplifier's front panel.

Screens

Channel Configuration Screens

1. Figure 15 is a graphic representation of the amplifier's output CHANNEL CONFIGURATION. Inputs (Q) are from Q-SYS, outputs A–D (E–H not shown) represent the amplifier channels and their configuration.
2. Text indicating how many channels, and the output configuration. For possible configurations refer to the Q-SYS help for the amplifier components.
3. Status of the amplifier and Q-SYS design indicating the design and amp are in sync.

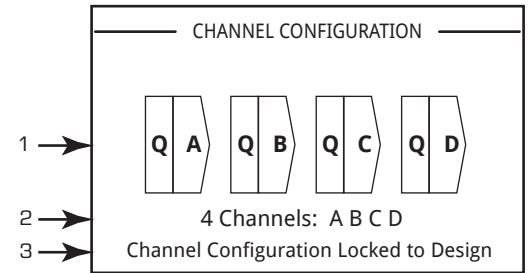

— Figure 15 —

Routeable MIC/LINE Inputs

This screen is not available on the DPA-Qn model amplifiers.

Figure 16 shows the Routeable MIC/LINE INPUTS screen for channels 1–4, (channels 5–8 not shown) which displays the status of the physical MIC/LINE INPUTS for the Q models.

1. Input channels are identified numerically, 1–4 (and 5–8 not shown)
2. **Input Level** – is the Peak Input Level (dBFS) and is the same as displayed in the Q-SYS Mic/Line Input component.
3. **Muted** – when illuminated indicates that the Input is muted for the associated channel. This is controlled by the Mute button on the Q-SYS Designer Mic/Line Input component. *Input channels cannot be muted from the amplifier interface.*
4. **Clip** – indicators illuminate when the input to the Mic/Line Input component is too high. Adjust the Preamp Gain on the Mic/Line Input component in Q-SYS Designer.
5. **P12** – phantom power (+12V) is available for microphones (condenser) requiring power. You can turn the phantom power on/off in the Mic/Line Input component in Q-SYS Designer.

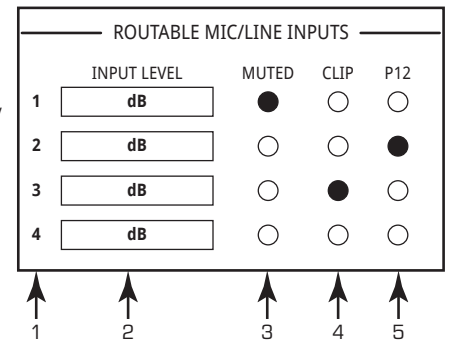

— Figure 16 —

Status Screen

Refer to Figure 17

1. **DEVICE** – the hostname (network name) of the amplifier. A default name is given at the factory, similar to the example. You may change the name in the Q-SYS Configurator.
2. **DESIGN** – the name of the Q-SYS design currently running on the amplifier. The amplifier must be contained in a running design to operate.
3. **STATUS** – displays the current status of the amplifier both in text and color. The following is a list of possible status colors, and some example conditions.
 - **OK** – green – audio is good, hardware is good.
 - **Compromised** – orange – audio is good but a redundancy mechanism is active (one LAN down but the other is still up) or a non-fatal hardware problem exists (fan speed, high temperature, low AC voltage, output load, amplifier is in Protect mode, etc.)
 - **Fault** – red – audio is not passing, or hardware is malfunctioning or mis-configured (amplifier power off, audio streams broken, amplifier fault, loudspeaker short circuit, etc.)
 - **Initializing** – blue – In the process of initialization, and design start. Audio is not passed.
4. **FIRMWARE** – the Q-SYS Designer firmware version installed on the amplifier.

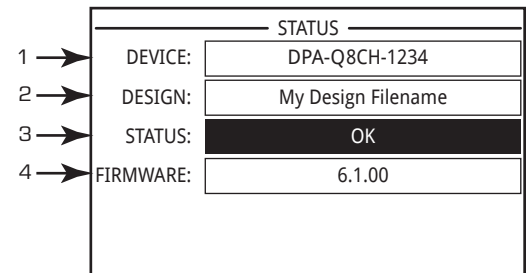

— Figure 17 —



NOTE: The DPA-Q 8-channel amplifiers require Version 6.1.1 or later of Q-SYS Designer.

To Update the Amplifier Firmware:

- a. Install the version of Q-SYS Designer you want to use on your PC.
- b. The amplifier must be connected to Q-LAN and turned on.
- c. Open the Q-SYS design containing the amplifier in the Designer version you just installed.
- d. Select "Save to Core and Run" from the File menu.
- e. The amplifier and any other Q-SYS peripherals in the design are automatically updated.

LAN A / LAN B Screen

Refer to Figure 18

1. **IP ADDRESS** – a default address is assigned in the factory. You can change this and the other parameters in Q-SYS Configurator. LAN A is required, and cannot be turned off.
2. **NETMASK** – must be the same as the Core's Netmask.
3. **GATEWAY** – must be the same as the Core's Gateway.
4. **LAN B** is not required. When connected, the same type of information as LAN A is displayed.

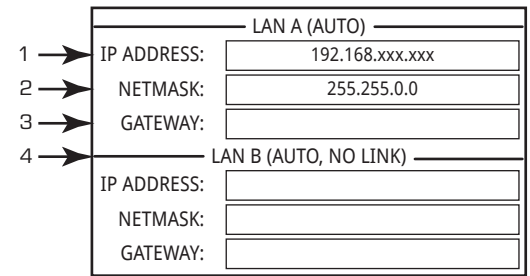

— Figure 18 —

Health Screen

Refer to Figure 19

1. **FAN RPM** – varies depending on the temperature.
2. **PSU TEMP** – varies depending on operating conditions. PSU Temp is monitored and can automatically put the amp into limiting or shutdown if safe operating temperatures are exceeded.
3. **AC VOLTAGE** – AC Mains voltage
4. **AC CURRENT** – AC mains current drawn by the amplifier.
5. Voltage Rails
 - **V RAIL 1** = +147VDC +/- 5V typical
 - **V RAIL 2** = -147VDC +/- 5V typical

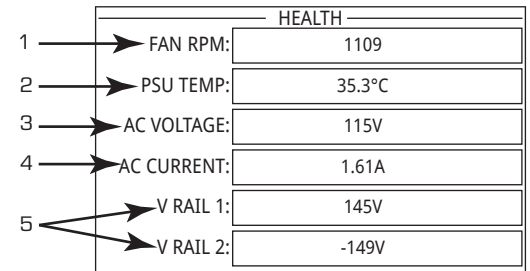

— Figure 19 —

OUTPUT GAINS Screen

Refer to Figure 20

The OUTPUT GAINS screens provide a quick overview of all outputs. In addition, when this screen is displayed, you can make gain adjustments from the amplifier's front panel. There is one screen for channels A–D and one for channels E–H.

Use the NEXT or PREV buttons to access these screens, or press one or more of the SEL buttons to access the screen.

1. The highlighted background indicates that the Channel is selected by the SEL button.
2. **Channel** – the channels display according to the configuration of the amplifier.
3. **Output Gain** – the output gain can be controlled in two places: the GAIN knob on the amplifier front panel and with the Gain control in the amplifier's Output component in the Q-SYS design.
4. **Q-LAN** Input Level – the level of the audio signal applied to the Output component in the Q-SYS design. The DPA-Q Output component is the connection to the output section of the amplifier.
5. **VOLTS** – the voltage applied to that output.
6. In the example Output B is combined with Output A – (AB or A+B), the slot for Output B is blank.

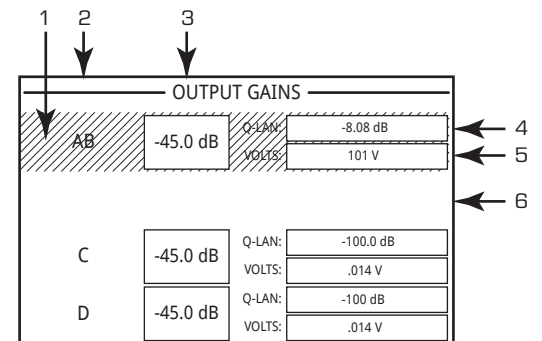

— Figure 20 —

To Make Gain Adjustments:

- a. Use the SEL button to select one or more channels. You can select any or all channels.
- b. Use the GAIN knob to make adjustments on the output gain of the selected channels.



NOTE: If the gains were the same when you select multiple channels the gains remain equal as you adjust them. If the gains are different, they keep their relative separation until one reaches a limit. At this point the other channel(s) continue to change until they reach the limit.



NOTE: If you press one or more of the SEL buttons, and do not make any GAIN adjustments, this screen remains visible for a short time then returns to the previous screen.

OUTPUT Screens

Each group of outputs has a dedicated screen. Figure 21 is an example of Outputs A – D.

1. Output channel identifiers **A – D and E – H** (not shown).
2. **DAC** – when illuminated, this indicates that the signal to the D to A Converter is larger than can be reproduced and a limiter has been engaged to prevent clipping.
3. **PROTECT** – when illuminated, this indicates that the amplifier is in Protect Mode. Usually due to the power supply going above its thermal threshold.
4. **LIMIT** – when illuminated, this indicates the amplifier limiter is active. There are five conditions that could cause the LIMIT condition:
 - Power
 - Current
 - Voltage
 - Temperature
 - Loudspeaker Protection is active.
5. **SHORT** – when illuminated, this indicates the output is shorted. A short can be triggered by either of the following:
 - a. Output impedance is below $\frac{1}{4}$ Ohm for more than 1 second.
 - b. Output voltage is less than 50% of what the DSP was expecting for more than 1 second.
6. Displays the temperature, in Centigrade, of the associated channel.

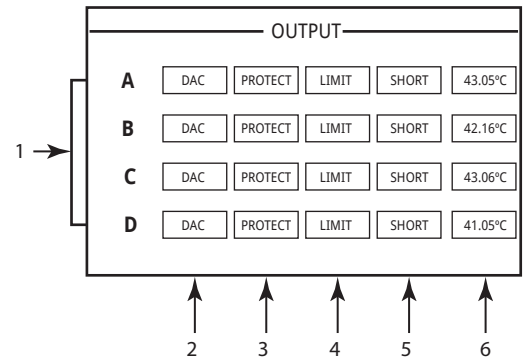

— Figure 21 —

GPIO

There are 16 General Purpose Input Output pins for use in various applications. Figure 22 shows the pin configuration for the connector on the rear of the amplifier. Table 1 shows the connector pin-out. Figure 23 gives some simple GPIO applications.

— Table 1 —

Connector Pin	GPIO # and Function	Specifications
1	3.3 V	100 mA max (power cycle to reset current limiting)
2	GPIO 1	5mA in/out, 3.3V max, 127Ω resistor in series
3	GPIO 2	5mA in/out, 3.3V max, 127Ω resistor in series
4	GND	Ground
5	GPIO 3	5mA in/out, 3.3V max, 127Ω resistor in series
6	GPIO 4	5mA in/out, 3.3V max, 127Ω resistor in series
7	GND	Ground
8	GPIO 5	18mA in/out max, 3.3V max, 127Ω resistor in series
9	RELAY NO ¹	Relay Normally Open
10	RELAY COM ¹	Relay Common
11	RELAY NC ¹	Relay Normally Closed
12	GND	Ground
13	GPIO 6	18mA in/out max, 3.3V max, 127Ω resistor in series
14	GPIO 7	18mA in/out max, 3.3V max, 127Ω resistor in series
15	GND	Ground
16	GPIO 8	18mA in/out max, 3.3V max, 127Ω resistor in series

¹ Nominal switching capacity is 30 VDC at 2 A for a total of 60 W maximum. The maximum voltage is 220 VDC if the current is limited to observe the maximum power rating (60 W).

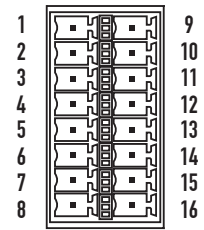

— Figure 22 —

Examples

Button or Contact Closure

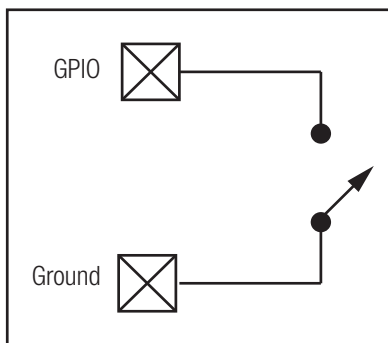

Potentiometer

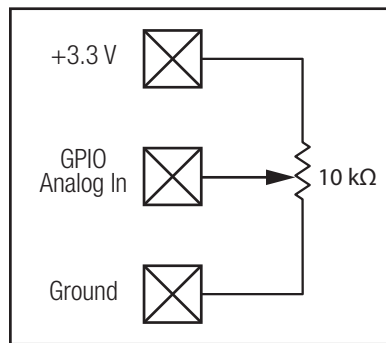

Q-SYS-Powered LED

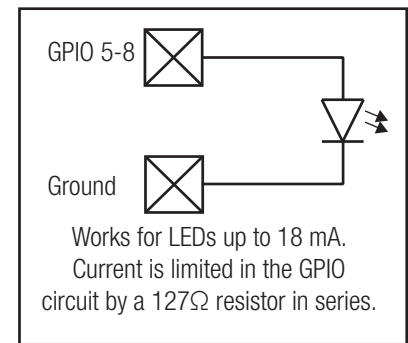

— Figure 23 —

Specifications

Channel Configuration	DPA8.4Q / DPA8.4Qn			DPA8.8Q / DPA8.8Qn	
		Max Power ¹	Continuous ²	Max Power ¹	Continuous ²
8 Independent Channels A, B, C, D, E, F, G, H	70 V	500 W	300 W	850 W	600 W
	100 V	500 W	300 W	850 W	600 W
	8Ω	500 W	300 W	850 W	600 W
	4Ω	500 W	300 W	1000 W	600 W
	2Ω	500 W	300 W	600 W	300 W
2 Channels Combined in BTL Bridge A+B or C+D or E+F or G+H Doubles Voltage	8Ω	1000 W ³	600 W ³	2000 W ³	1200 W ³
	4Ω	NR ⁴	NR ⁴	NR ⁴	NR ⁴
	2Ω	NR ⁴	NR ⁴	NR ⁴	NR ⁴
2 Channels Combined in Parallel AB or CD or EF or GH Doubles Current	8Ω	1000 W	600 W	1100 W	1100 W
	4Ω	1000 W ³	600 W ³	1800 W ³	1200 W ³
	2Ω	1000 W ³	600 W ³	2000 W ³	600 W ³
3CH Combined in Parallel ABC or EFG Triples Current	8Ω	1000 W	900 W	1100 W	1100 W
	4Ω	1500 W	900 W	1800 W	1800 W
	2Ω	1500 W	900 W	2800 W	1800 W
4CH Combined in Bridged/Parallel AB+CD Doubles Current and Voltage	8Ω	2000 W ³	1200 W ³	3600 W ³	2400 W ³
	4Ω	2000 W ³	1200 W ³	4500 W ³	2400 W ³
	2Ω	NR ⁴	NR ⁴	NR ⁴	NR ⁴
4CH Combined in Parallel ABCD or EFGH Quadruples Current	8Ω	1200 W	1200 W	1200 W	1200 W
	4Ω	2000 W	1200 W	2200 W	2200 W
	2Ω	2000 W ³	1200 W ³	4000 W ³	2400 W ³
		DPA8.4Q / DPA8.4Qn		DPA8.8Q / DPA8.8Qn	
Typical distortion					
8Ω		0.02 – 0.05%		0.02 – 0.05%	
4Ω		0.04 – 0.1%		0.04 – 0.1%	
Maximum distortion					
4Ω - 8Ω		1.0%		1.0%	
Frequency response (8Ω)		20 Hz – 20 kHz +/- 0.3 dB		20 Hz – 20 kHz +/- 0.3 dB	
Noise					
Unweighted output muted		>101 dB		>101 dB	
Weighted output muted		>104 dB		>104 dB	
Gain (1.2V setting)		35.4 dB		38.4 dB	
Damping factor		>100		>100	
Input impedance		>8kΩ balanced and >4kΩ unbalanced		>8kΩ balanced and >4kΩ unbalanced	
Input Sensitivity		Vrms 1.23mV to 17.35V		Vrms 1.23mV to 17.35V	
Continuously variable:		dBu -56 to 27		dBu -56 to 27	
		dBv -58.2 to 24.8		dBv -58.2 to 24.8	
Controls and indicators (front)		Power • Channel MUTE Buttons • Channel SELECT Buttons • Channel Input Signal and CLIP LED Indicators • Channel Output and LIMIT LED Meters • NEXT, PREV, ID Buttons • Control Knob • Reset Button			
Controls and indicators (rear)		AC Power Disconnect (IEC Power cord and/or AC Power switch)			
Input connectors		3-pin Phoenix			
Output connectors		8-pin Phoenix Speaker			
Amplifier and load protection		Short circuit • open circuit • thermal • RF protection • On/Off muting • DC fault shutdown • active inrush limiting			
AC power input		Universal input power supply with active power factor correction 100 - 240 VAC, 50 - 60 Hz			

	DPA8.4Q / DPA8.4Qn	DPA8.8Q / DPA8.8Qn
Weight, net / shipping	25 lb (11.3 kg) / 29 lb (13.2 kg)	26 lb (11.8 kg) / 30 lb (13.6 kg)
Dimensions (HWD)	3.5" x 19" x 16" (89mm x 482mm x 406mm)	
Agency approvals	UL • CE • RoHS/WEEE compliant • FCC Class B (conducted and radiated emissions)	
Carton contents	Quick-Start Guide • Safety Sheet • Amplifier • Power Cord • Euro-style Connector Plug, 3-pin • Euro-style Connector Plug, 8-pin • Euro-style Connector Plug, 3.5 mm, 16-pin	

- 1 Max Power – 20 ms 1 kHz sine burst, all channels driven
- 2 Continuous Power – EIA 1 kHz 1% THD, all channels driven
- 3 **BOLD** = Optimal configuration for the load and channel count
- 4 NR = Not Recommended due to excessive current draw

Heat Loss and Current-Draw Charts

Heat losses are the thermal emissions from an amplifier while it is operating. It comes from dissipated waste power—i.e., real AC power in minus audio power out. Measurements are provided for various loads at idle, 1/8 of average full power, 1/3 of average full power, and full power, with all channels driven simultaneously. For typical usage, use the idle and 1/8 power figures. This data is measured from representative samples; due to production tolerances, actual heat emissions may vary slightly from one unit to another. Bridged mono into 8 ohms is equivalent to 4 ohms per channel; into 4 ohms is equivalent to 2 ohms per channel.

Idle

Thermal loss at idle or with very low signal level.

1/8 Power

Thermal loss at 1/8 of full power is measured with a 1 kHz sine wave signal. It approximates operating with music or voice with light clipping and represents the amplifier's typical "clean" maximum level, without audible clipping. Use these figures for typical maximum level operation.

1/3 Power

Thermal loss at 1/3 of full power is measured with pink noise. It approximates operating with music or voice with very heavy clipping and a very compressed dynamic range.

Full Power

Thermal loss at full power is measured with a 1 kHz sine wave. However, it does not represent any real-world operating condition.

Current Draw

The amount of AC current an amplifier demands while it is operating. Measurements are provided for various loads at idle, 1/8 of average full power, 1/3 of average full power, and full power, with all channels driven simultaneously. The data shown in the following tables is listed for 100VAC, 120VAC and 230VAC operation. For typical usage, use the idle and 1/8 power data.

100VAC Operation

Load per Channel				8Ω			4Ω			2Ω		
	BTU/hr	kcal/hr	Amperes	BTU/hr	kcal/hr	Amperes	BTU/hr	kcal/hr	Amperes	BTU/hr	kcal/hr	Amperes
Idle												
DPA8.4Q / DPA8.4Qn	543	137	1.7									
DPA8.8Q / DPA8.8Qn	631	159	1.0									
1/8th Power												
DPA8.4Q / DPA8.4Qn				971	245	6.2	1132	285	6.7	1399	353	7.5
DPA8.8Q / DPA8.8Qn				1273	321	10.8	1277	322	11.0	1457	367	8.9
1/3rd Power												
DPA8.4Q / DPA8.4Qn				1447	365	13.1	1802	454	14.3	2297	579	15.7
DPA8.8Q / DPA8.8Qn				1806	455	23.0	2199	552	23.8	2451	618	16.7
Full Power												
DPA8.4Q / DPA8.4Qn				2526	637	33.9	3768	950	37.1	5795	1460	43.6
DPA8.8Q / DPA8.8Qn				6986	1760	74.9	8065	2032	77.9	4925	1241	40.2

120VAC Operation

Load per Channel				8Ω			4Ω			2Ω		
	BTU/hr	kcal/hr	Amperes	BTU/hr	kcal/hr	Amperes	BTU/hr	kcal/hr	Amperes	BTU/hr	kcal/hr	Amperes
Idle												
DPA8.4Q / DPA8.4Qn	548	138	1.4									
DPA8.8Q / DPA8.8Qn	642	162	1.6									
1/8th Power												
DPA8.4Q / DPA8.4Qn				942	237	5.0	1100	277	5.4	1385	349	6.1
DPA8.8Q / DPA8.8Qn				1352	341	9.4	1317	332	9.4	1519	383	8.0
1/3rd Power												
DPA8.4Q / DPA8.4Qn				1362	343	10.5	1700	428	11.4	2259	569	12.6
DPA8.8Q / DPA8.8Qn				1976	498	19.3	2474	623	20.3	2461	620	14.0
Full Power												
DPA8.4Q / DPA8.4Qn				2601	655	27.3	3304	833	29.1	5546	1398	34.6
DPA8.8Q / DPA8.8Qn				5140	1295	55.0	6137	1547	57.4	4358	1098	31.9

230VAC Operation

Load per Channel				8Ω			4Ω			2Ω		
	BTU/hr	kcal/hr	Amperes	BTU/hr	kcal/hr	Amperes	BTU/hr	kcal/hr	Amperes	BTU/hr	kcal/hr	Amperes
Idle												
DPA8.4Q / DPA8.4Qn	546	138	0.9	—	—	—	—	—	—	—	—	—
DPA8.8Q / DPA8.8Qn	580	146	1.2	—	—	—	—	—	—	—	—	—
1/8th Power												
DPA8.4Q / DPA8.4Qn				889	224	2.6	1008	254	2.8	1253	316	3.1
DPA8.8Q / DPA8.8Qn				1290	325	5.0	1399	353	5.1	1556	392	5.4
1/3rd Power												
DPA8.4Q / DPA8.4Qn				1399	353	5.5	1621	408	5.9	2020	509	6.4
DPA8.8Q / DPA8.8Qn				1980	499	10.1	2263	570	10.3	2164	545	7.6
Full Power												
DPA8.4Q / DPA8.4Qn				2280	575	13.9	2826	712	14.5	4730	1192	17.0
DPA8.8Q / DPA8.8Qn				3748	944	26.3	4638	1169	27.5	3843	968	16.4

**Mailing Address:**

QSC, LLC
1675 MacArthur Boulevard
Costa Mesa, CA 92626-1468 U.S.
Main Number: +1.714.754.6175
World Wide Web: www.qsc.com

Sales & Marketing:

Voice: +1.714.957.7100 or toll free (U.S. only) 1.800.854.4079
FAX: +1.714.754.6174
E-mail: info@qsc.com

Q-SYS™ Customer Support**Application Engineering and Technical Services**

Monday - Friday 7 AM to 5 PM PST (Excludes Holidays)
Tel. 1.800.772.2834 (U.S. only)
Tel. +1.714.957.7150

Q-SYS 24/7 Emergency Support*

Tel: +1.888.252.4836 (U.S./Canada)

Tel: +1.949.791.7722 (non-U.S.)

*Q-SYS 24/7 Support is for Emergency assistance with Q-SYS systems only. 24/7 support guarantees a call back within 30 min after a message is left. Please include, Name, Company, Call Back Number and description of the Q-SYS emergency for prompt call back. If calling during business hours please use the standard support numbers above.

Q-SYS Support Email

qsysupport@qsc.com

(Immediate email response times not guaranteed)

QSC

Technical Services

1675 MacArthur Blvd.

Costa Mesa, CA 92626 U.S.

Tel: 1.800.772.2834 (U.S. only)

Tel: +1.714.957.7150

FAX: +1.714.754.6173

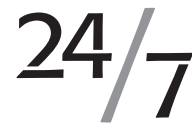

Q-Sys™ Customer Support